

MOL#23994

Specific Rescue of CFTR Processing Mutants Using Pharmacological Chaperones

Ying Wang, M. Claire Bartlett, Tip W. Loo and David M. Clarke

Department of Medicine and Department of Biochemistry, University of Toronto, Toronto,
Ontario. M5S 1A8. Canada

MOL#23994

Running title: Specific Chaperones for CFTR

Corresponding Author:

David M. Clarke

Department of Medicine

University of Toronto

Rm. 7342, 1 King's College Circle

Toronto, Ontario. M5S 1A8

CANADA

Tel: 416-978-1105

FAX: 416-978-1105

E-mail: david.clarke@utoronto.ca

Number of text pages: 25

Number of tables: 0

Number of figures: 7

Number of references: 28

Number of words in Abstract: 232

Number of words in Introduction: 423

Number of words in Discussion: 755

Abbreviations: CFTR, cystic fibrosis transmembrane conductance regulator; CFcor-325, 4-cyclohexyloxy-2-{1-[4-(4-methoxy-benzenesulfonyl)-piperazin-1-yl]-ethyl}-quinazoline; CFpot-532, 4-methyl-2-(5-phenyl-1H-pyrazol-3-yl)-phenol; corr-2b, 2-phenylamino-4-(4-ethylene-phenyl)-thiazole.

MOL#23994

Abstract

Most mutants of the cystic fibrosis transmembrane conductance regulator (CFTR) that cause severe symptoms of cystic fibrosis do not reach the cell surface because they are defective in folding. Many CFTR folding mutants including the $\Delta F508$ mutant found in more than 90% of cystic fibrosis patients however, are potentially functional at the cell surface if they can be induced to fold correctly. In a previous study (Loo, T. W., Bartlett, M. C., and Clarke, D. M. (2005) *Mol. Pharm.* **2**, 407-413), we reported that a quinazoline derivative (CFcor-325) could rescue CFTR processing mutants. The corrector was not specific however, as it could also rescue a processing mutant of CFTR's sister protein, the multidrug resistance P-glycoprotein. The goal of this study was to test whether it was possible to specifically rescue CFTR processing mutants using a pharmacological chaperone. Here, we report that two compounds, 4-methyl-2-(5-phenyl-1H-pyrazol-3-yl)-phenol (CFpot-532) and 2-phenylamino-4-(4-ethylene-phenyl)-thiazole (corr-2b) could rescue CFTR processing mutants such as $\Delta F508$ CFTR but not a P-glycoprotein processing mutant. The compound CFpot-532 also acts as a potentiator of $\Delta F508$ CFTR channel activity. Therefore, the results suggest that the mechanism whereby CFpot-532 and corr-2b promote folding of CFTR processing mutants is through direct interaction with the CFTR mutant proteins. The compound CFpot-532 could be a particularly useful lead compound for treatment of cystic fibrosis because it is both a CFTR channel activator as well as a specific pharmacological chaperone.

MOL#23994

Introduction

The cystic fibrosis transmembrane conductance regulator (CFTR) is a cAMP-regulated chloride channel located in the apical membrane of many epithelial cells where it plays a key role in regulating salt and water homeostasis (Akabas, 2000). Defects in CFTR biosynthesis or channel activity due to inherited mutants lead to the development of cystic fibrosis (Riordan et al., 1989). Cystic fibrosis is a lethal genetic disease because chronic lung infections lead to deterioration and eventual failure of the lungs.

One particular mutation, deletion of phenylalanine 508 ($\Delta F508$), is found on at least one chromosome in 90% of cystic fibrosis patients (Bobadilla et al., 2002). The $\Delta F508$ CFTR protein is defective in folding, so it is retained in the endoplasmic reticulum and then rapidly degraded (Cheng et al., 1990; Ward and Kopito, 1994). Early studies showed that it was possible to increase the efficiency of folding of $\Delta F508$ CFTR to yield functional molecules at the cell surface through expression at low temperature (27 °C) (Denning et al., 1992) or in the presence of non-specific osmolytes such as glycerol (Brown et al., 1996; Riordan et al., 1989; Sato et al., 1996) or in the presence of organic solutes such as myoinositol (Zhang et al., 2003). Studies on processing mutants of CFTR's sister protein, the multidrug resistance P-glycoprotein (P-glycoprotein), showed that specific pharmacological chaperones could be used to rescue mutants defective in folding (Loo et al., 2005; Loo and Clarke, 1997). Therefore, high-throughput screening of chemical libraries was performed to identify pharmacological chaperones that could promote folding of CFTR processing mutants such as $\Delta F508$ (Pedemonte et al., 2005; Van Goor et al., 2006). One particularly efficient pharmacological chaperone that promotes folding of CFTR processing mutants is CFcor-325 (Loo et al., 2005; Loo et al., 2006; Loo and Clarke, 2005b; Van Goor et al., 2006). Expression of $\Delta F508$ CFTR in the presence of 1-10 μM CFcor-

MOL#23994

325 promoted maturation of the protein to yield functional channels at the cell surface. The chaperone was not specific however, as it also promoted maturation of a P-glycoprotein processing mutant. Therefore, it was possible that CFcor-325 could be acting nonspecifically on a cellular pathway to cause a general effect on protein folding. In this study, we tested whether it was possible to specifically rescue $\Delta F508$ CFTR with a pharmacological chaperone that did not promote maturation of P-glycoprotein. A variety of recently identified CFTR high affinity pharmacological chaperones such as corr-2b, corr-3a, corr-4a and corr-4b (Pedemonte et al., 2005) were tested along with a new pyrazole-type CFTR channel activator, CFpot-532 (Van Goor et al., 2006).

MOL#23994

Materials and Methods

Expression of Mutants. Wild-type, Δ F508 and H1085R CFTR cDNAs were inserted into the pcDNA3 vector (Invitrogen, Oakville, ON) as described previously (Loo et al., 2006). Wild-type and mutant G268V P-glycoprotein cDNAs were inserted into the pMT21 vector (Genetics Institute, Boston, MA) as described previously (Loo and Clarke, 1994). Baby hamster kidney (BHK) cells stably expressing CFTR or P-glycoprotein were generated by cotransfection of the cDNA with pWL-neo (Stratagene, Cedar Creek, TX) and selection with 1 mg/ml G418. The G418-resistant clones expressing CFTR or P-glycoprotein were identified by subjecting cell extracts to immunoblot analysis with rabbit polyclonal antibody against CFTR or P-glycoprotein (Chen et al., 2004; Loo and Clarke, 1995a). Transient expression of CFTR or P-glycoprotein was carried out by transfection of HEK 293 cells.

To test for the effect of pharmacological chaperones on expression of CFTR or P-glycoprotein processing mutants, cells were grown to about 75% confluency in Dulbecco's modification of Eagle's medium (DMEM) with 2% (v/v) calf serum at 37 °C. Various concentrations of CFcor-325, CFpot-532 (Vertex Pharmaceuticals, San Diego, CA), corr-2b, corr-3a, corr-4a or corr-4b (Chem Div, San Diego, CA) in DMEM with 2% (v/v) calf serum were then applied to the cells. The cells were harvested after 24-72 h and solubilized with 2 X SDS sample buffer (125 mM Tris-HCl, pH 6.8, 20% (v/v) glycerol, 4% (w/v) SDS and 4% (v/v) 2-mercaptoethanol) containing 50 mM EDTA. Samples were then subjected to SDS-PAGE (5.5% acrylamide gels) and immunoblot analysis with rabbit polyclonal antibody against CFTR or P-glycoprotein. The amount of mature CFTR relative to total (mature plus immature CFTR) was quantitated by scanning the gel lanes followed by analysis with the NIH Image program (available at <http://rsb.info.nih.gov/nih-image1>) using a Macintosh computer.

MOL#23994

Treatment with Endoglycosidases. Cells expressing CFTR or P-glycoprotein were lysed with 2 X SDS sample buffer containing 50 mM EDTA. For treatment with endoglycosidase H (endo H), a one-tenth volume of 0.5 M sodium citrate, pH 5.5 was added to cell extract followed by addition of 20,000 U/ml of endo H (New England Biolabs, Mississauga, ON). The sample was treated for 15 min at 20 °C. For treatment with peptide N-glycosidase F (PNGase F), a one-tenth volume of 0.5 M sodium phosphate, pH 7.5, and one-tenth volume of 10% (v/v) NP-40 were added to the cell extract followed by addition of 10,000 U/ml of PNGase F (New England Biolabs, Mississauga, ON). The sample was incubated for 15 min at 37 °C. Samples were then subjected to immunoblot analysis with anti-CFTR monoclonal antibody M3A7 and enhanced chemiluminescence.

Iodide Efflux Assays. Measurement of cAMP-stimulated iodide efflux was performed on BHK cells stably expressing CFTR protein or COS-1 cells transiently transfected with CFTR cDNAs as described previously (Loo et al., 2005).

Isolation of P-glycoprotein and Measurement of Drug-stimulated ATPase Activity. Histidine-tagged P-glycoprotein was isolated by nickel-chelate chromatography as described previously (Loo and Clarke, 1995b). An aliquot of the isolated histidine-tagged P-glycoprotein was mixed with an equal volume of 10 mg/ml sheep brain phosphatidylethanolamine (Type II-S, Sigma-Aldrich, Mississauga, ON) that had been washed and suspended in Tris-buffered saline, pH 7.4 (10 mM Tris-HCl, pH 7.4, 150 mM NaCl) containing 2 mM dithiothreitol. The P-glycoprotein/lipid mixture was then sonicated for 45 s at 4 °C. A sample of the mixture was then incubated in the presence of various concentrations (0-0.3 mM) of CFcor-325, CFpot-532, corr-2b, corr-3a, corr-4a, corr-4b. ATPase activity was initiated by addition of an equal volume of ATPase buffer containing 100 mM Tris-HCl, pH 7.5, 100 mM NaCl, 20 mM MgCl₂ and 10 mM

MOL#23994

ATP with and without 0.6 mM verapamil. A final concentration of 0.3 mM verapamil was saturating and resulted in maximal activation of ATPase activity (Loo and Clarke, 2001). The samples were incubated at 37 °C for 30 min followed by measurement of the amount of inorganic phosphate that was released.

MOL#23994

Results

The pyrazole derivative 4-methyl-2-(5-phenyl-1H-pyrazol-3-yl)-phenol (CFpot-532) (Fig. 1A) was identified as a Δ F508 CFTR channel activator during high-throughput screening for compounds that stimulate cAMP-mediated channel activity ('potentiators') using mouse NIH 3T3 cells (Van Goor et al., 2006). Since it is difficult to stimulate Δ F508 CFTR channel activity after low temperature rescue in some cell lines with cAMP agonists such as forskolin (Bebok et al., 2005; Pedemonte et al., 2005), we tested whether CFpot-532 could enhance channel activity of Δ F508 CFTR. BHK cells stably expressing Δ F508 CFTR were used because they do not express detectable amounts of endogenous CFTR. Δ F508 CFTR was expressed in BHK cells for 48 h at 27 °C to promote maturation of the protein and delivery to the cell surface (Loo et al., 2004). CFTR channel activity was monitored using iodide efflux assays since few channels other than CFTR can conduct iodide ions (Gupta et al., 2001). Fig. 2 shows that little iodide efflux could be detected after stimulation with forskolin. Iodide efflux, however, was greatly increased when 10 μ M CFpot-532 was included in the stimulation buffer. No enhanced iodide efflux could be detected in BHK control cells or in Δ F508 CFTR expressing BHK cells that were not incubated at low temperature. In the absence of forskolin, CFpot-532 did not increase channel activity suggesting that it acts as a potentiator. The ability of CFpot-532 to enhance channel activity suggests that it directly binds to CFTR.

Compounds that can directly bind to an ABC transporter have the potential to act as specific pharmacological chaperones to promote folding of processing mutants (Loo et al., 2006; Loo and Clarke, 1997). Therefore we tested whether expression of Δ F508 CFTR in the presence of CFpot-532 would promote maturation of the protein. Since CFTR is N-glycosylated at two sites (Fig. 1B), maturation of the protein can be monitored by a difference in mobility on SDS-PAGE

MOL#23994

gels between the core-glycosylated immature protein and the mature protein containing complex carbohydrate. BHK cells stably expressing $\Delta F508$ CFTR were incubated for 48 h in the presence of various concentrations of CFpot-532. Whole cell SDS extracts were then subjected to immunoblot analysis with an anti-CFTR antibody. Fig. 3A shows that CFpot-532 appeared to promote maturation of $\Delta F508$ CFTR as there was a dose-dependent increase in a slower migrating species of immunoreactive protein that corresponded in size to mature CFTR.

To test if the slower migrating immunoreactive protein that was induced by the presence of CFpot-532 corresponded to mature CFTR, we carried out endoglycosidase analysis. CFTR that is retarded in the endoplasmic reticulum is only core-glycosylated and is sensitive to digestion with endo H. Mature CFTR however contains complex carbohydrate groups that are resistant to endo H but sensitive to PNGase F. As controls, we included $\Delta F508$ CFTR samples that had been rescued with the pharmacological chaperones CFcor-325 (Loo et al., 2005) and corr-4a (Pedemonte et al., 2005). We compared the efficiency of rescue (Fig. 3B, - lanes) by quantitating the amount of mature CFTR relative to the total amount of CFTR. The amount of mature $\Delta F508$ CFTR protein increased from less than 2% in the absence of drug to $11 \pm 3\%$, $21 \pm 4\%$, $27 \pm 6\%$ when it was expressed in the presence of CFpot-532, corr-4a or CFcor-325 respectively. In comparison, only $17 \pm 5\%$ of the total CFTR was in the mature form when $\Delta F508$ CFTR expressed in BHK cells were incubated for 24 h at 27 °C (data not shown). Fig. 3B shows that the 170 kDa immature $\Delta F508$ CFTR was sensitive to both endo H and PNGase F whereas the 190 kDa immunoreactive product was only sensitive to PNGase F. Therefore, expression of $\Delta F508$ CFTR in the presence of CFpot-532 induced maturation to yield the mature form of the protein.

MOL#23994

Next we tested whether $\Delta F508$ was active at the cell surface after rescue with CFpot-532. BHK cells stably expressing $\Delta F508$ CFTR were treated for 48 h with or without 10 μM CFpot-532 and then used in iodide efflux assays. The cells were loaded with sodium iodide and cAMP-stimulated iodide efflux was measured. Fig. 4 shows that BHK cells expressing $\Delta F508$ CFTR demonstrated iodide efflux activity only when expressed in the presence of CFpot-532 (Fig. 4). These results show that CFpot-532 induced maturation and trafficking of $\Delta F508$ CFTR to the cell surface in an active form.

The next step was to test whether CFpot-532 was specific for rescue of CFTR using a processing mutant of P-glycoprotein (P-glycoprotein), a sister protein of CFTR as a control. We used the G268V P-glycoprotein processing mutant rather than mutant $\Delta Y490$ P-glycoprotein (equivalent to $\Delta F508$ in CFTR) as a control because maturation of the G268V mutant is not promoted by nonspecific conditions such as growth at low temperature (27 °C) or expression in the presence of osmolytes such as glycerol or trimethylamine-N-oxide. Maturation of mutant G268V to yield active enzyme at the cell surface can be achieved however, by carrying out expression in the presence of drug substrates (Loo and Clarke, 1999a). Accordingly, HEK 293 cells transiently expressing P-glycoprotein mutant G268V were incubated with 10 μM CFpot-532 for 48 h. In addition, we tested whether other classes of recently identified CFTR pharmacological chaperones such as corr-2b, corr-3a, corr-4a and corr-4b (Pedemonte et al., 2005) would also rescue P-glycoprotein mutant G268V. The pharmacological chaperone CFcor-325 was included as a control as it rescues processing mutants of both CFTR and P-glycoprotein (Loo et al., 2005). In addition, the P-glycoprotein substrate cyclosporin A was included as a positive control.

MOL#23994

Immunoblot analysis of whole cell extracts expressing P-glycoprotein mutant G268V in the presence or absence of pharmacological chaperone is shown in Fig. 5. In the absence of drugs, P-glycoprotein mutant G268V is expressed as a 150 kDa immature product (>95% of total P-glycoprotein). Expression of P-glycoprotein G268V in the presence of CFcor-325 or corr-3a caused a large increase in the level of mature 170 kDa protein ($45 \pm 7\%$ and $73 \pm 11\%$ respectively of total P-glycoprotein). Reduced levels of mature P-glycoprotein were observed when the mutant was expressed in the presence of pharmacological chaperones corr-4a ($17 \pm 4\%$ mature P-glycoprotein) or corr-4b ($31 \pm 7\%$ mature P-glycoprotein). No detectable increase in expression of mature P-glycoprotein was observed however when the mutant was expressed in the presence of CFpot-532 or corr-2b (Fig. 5). Therefore, the pharmacological chaperones CFpot-532 and corr-2b were specific for correction of $\Delta F508$ CFTR.

To test if pharmacological chaperones that could rescue P-glycoprotein mutant G268V showed a direct interaction with the protein, ATPase assays were performed since many P-glycoprotein substrates will stimulate its ATPase activity (Loo and Clarke, 2001). We also tested for interactions by monitoring inhibition of verapamil-stimulated ATPase activity. Verapamil was selected because it is one of the most potent activators of P-glycoprotein ATPase activity (Loo and Clarke, 2001). Wild-type histidine-tagged P-glycoprotein was expressed in HEK 293 cells, isolated by nickel chromatography and suspended in lipid for assay of ATPase activity. No detectable stimulation of P-glycoprotein ATPase activity was observed with CFpot-532, corr-4a or corr-2b while compounds CFcor-325, corr-3a and corr-4b stimulated activity 2.0-, 3.8- and 2.7-fold respectively (Fig. 6A). It should be noted that relatively high concentrations of corrector (300 μM) were used in the ATPase assays to achieve maximal stimulation of ATPase activity. Concentrations required for 50% stimulation were $1.4 \pm 0.3 \mu\text{M}$, $7 \pm 0.9 \mu\text{M}$ and $20 \pm 1.2 \mu\text{M}$ for

MOL#23994

corr-3a, CFcor-325 and corr-4b, respectively. Next we tested for inhibition of P-glycoprotein verapamil-stimulated ATPase activity. Little or no inhibition of verapamil-stimulated ATPase activity was observed with CFpot-532 or corr-2b (Fig. 6B). A modest reduction in ATPase activity was observed with corr-4a ($26 \pm 6\%$ inhibition) while more potent inhibition was observed with corr-4b, CFcor-325 and corr-3a ($63 \pm 6\%$, $74 \pm 3\%$ and $53 \pm 5\%$ inhibition respectively). Therefore, compounds that promoted maturation of P-glycoprotein mutant G268V also had a direct effect on P-glycoprotein ATPase activity (CFcor-325, corr-3a, corr-4a, corr-4b), whereas compounds that did not promote maturation (CFpot-532, corr-2b) had no detectable effect on P-glycoprotein ATPase activity.

It has been reported that it was possible to specifically rescue CFTR processing mutants containing a processing mutation in the front half of the protein ($\Delta F508$) by co-expression with a CFTR NH₂-half molecule whereas processing mutations located in the back half of the protein (H1085R) could be rescued by co-expression with a CFTR COOH-half-molecule (Cornet-Boyaka et al., 2004). Apparently, the location of a processing mutation can be important for rescue. Therefore, we tested whether a specific CFTR pharmacological chaperone like CFpot-532 could rescue a CFTR processing mutant with a mutation in the COOH half of the molecule (H1085R). HEK 293 cells transiently expressing CFTR processing mutant H1085R were incubated in the presence or absence of 10 μ M CFpot-532 for 48 h. Whole cell extracts were subjected to immunoblot analysis. Fig. 7 shows that expression of CFTR H1085R in the presence of 10 μ M CFpot-532 promoted maturation of the protein. Therefore CFpot-532 can rescue processing mutants with mutations in either half of the molecule.

MOL#23994

Discussion

A potential therapy for cystic fibrosis would be to use specific high-affinity pharmacological chaperones to correct folding defects in CFTR processing mutants to yield functional channels at the cell surface. A potential candidate that was recently identified was CFcor-325 (Loo et al., 2005). Unfortunately, CFcor-325 was not specific for CFTR as it could also correct folding defects in processing mutants of P-glycoprotein. P-glycoprotein mutants are good reporter molecules to test for specific rescue of CFTR because P-glycoprotein mutants can be rescued with a wide variety of hydrophobic molecules (Loo and Clarke, 1997). CFcor-325 was shown to bind directly to P-glycoprotein because the compound inhibits drug transport (Loo et al., 2005). Although it was possible that CFcor-325 could also bind to CFTR to promote maturation, it was also possible that CFcor-325 could affect maturation through an indirect effect on a general folding pathway. Evidence in favor of a nonspecific effect of CFcor-325 on membrane protein folding was the observation that it could also promote maturation of a processing mutant (G601S) of the human ether-a-go-go (hERG) cardiac potassium channel (Van Goor et al., 2006).

The results from this study show that the pharmacological chaperones CFpot-532 and corr-2b could specifically rescue CFTR processing mutants without promoting maturation of a P-glycoprotein processing mutant. It is interesting to note that corr-2b and CFpot-532 share some structural similarities. Both compounds are small and consist of a central 5-member ring (pyrazole and thiazole for CFpot-532 and corr-2b respectively) with phenyl rings linked to two sites (Fig. 1A). Perhaps they could interact with CFTR at similar sites to correct folding. Although there is no direct evidence that corr-2b binds directly to CFTR as it does not activate CFTR channel activity (Pedemonte et al., 2005), CFpot-532 has been demonstrated to increase $\Delta F508$ CFTR channel activity (this study) (Van Goor et al., 2006). CFpot-532 acts as a CFTR

MOL#23994

potentiator because it only affects channel gating after addition of forskolin. The major effect of CFpot-532 on Δ F508 CFTR was to increase the open probability (P_o) of the channel (Van Goor et al., 2006). Treatment of Δ F508 CFTR with CFpot-532 in the presence of ATP and protein kinase A increased open probability 4 fold so that it was similar to the P_o of wild-type CFTR. It was recently shown that Δ F508 CFTR shows a 3-4 fold lower P_o than wild-type CFTR because the Phe508 aromatic side chain plays a key role in determining the residency time in the closed state (Cui et al., 2006). Although CFpot-532 was not as efficient a corrector of Δ F508 CFTR maturation compared to CFcor-325 or corr-4a (Fig. 3B), it has the ability to act as both a corrector and potentiator of CFTR processing mutants. Therefore it may be a good lead compound to try to make derivatives with better corrector abilities but retain its potentiator characteristics.

Examples of corrector compounds from two other classes of compounds such as corr-3a (2-quinazoliny-4-aminopyrimidinone) or corr-4a and corr-4b (bisaminomethylbithiazoles) were not specific for CFTR as they could also rescue the P-glycoprotein processing mutant. There was good correlation between compounds that promoted maturation of P-glycoprotein mutant G268V and those that affected its ATPase activity. Compounds CFcor-325, corr-3a, corr-4a and corr-4b all rescued P-glycoprotein G268V and could also stimulate or inhibit P-glycoprotein ATPase activity. Therefore, it is likely that they all rescue P-glycoprotein G268V through a direct interaction with the protein. We have previously demonstrated that P-glycoprotein processing mutants are rescued by substrates and modulators through interactions with the transmembrane domains (Loo and Clarke, 1999b). Therefore, we predict that specific rescue of CFTR processing mutants with CFpot-532 or corr-2b is mediated through interactions with the transmembrane domains.

MOL#23994

In a previous study, it had been postulated that bisaminomethylbithazoles such as corr-4a and corr-4b were specific pharmacological chaperones for CFTR because they did not rescue a dopamine receptor (DRD4) processing mutant (M345T) (Pedemonte et al., 2005). Our results show, however, that these compounds are not specific for CFTR because they could also rescue a P-glycoprotein processing mutant (G268V, Fig. 5).

In summary, the results show that some correctors are specific for CFTR (CFpot-532, corr-2b) whereas others such as CFcor-325 and corr-3a could rescue both CFTR and P-glycoprotein and may act through an indirect pathway. The ability to directly rescue CFTR processing mutants would be beneficial, as they would have less effect on other cellular processes. In addition, compounds that are not substrates of P-glycoprotein would be better candidates to administer orally to cystic fibrosis patients since they could bypass P-glycoprotein in the gut, liver and kidney (Loo and Clarke, 2005a).

MOL#23994

Acknowledgments

We thank the Cystic Fibrosis Foundation (U.S.A.) and Vertex Corporation (San Diego, CA) for the generous gift of CFcor-325 and CFpot-532.

MOL#23994

References

- Akabas MH (2000) Cystic fibrosis transmembrane conductance regulator. Structure and function of an epithelial chloride channel. *J Biol Chem* 275:3729-3732.
- Bebok Z, Collawn JF, Wakefield J, Parker W, Li Y, Varga K, Sorscher EJ and Clancy JP (2005) Failure of cAMP agonists to activate rescued Δ F508 CFTR in CFBE41o- airway epithelial monolayers. *J Physiol* 569:601-615.
- Bobadilla JL, Macek M, Jr., Fine JP and Farrell PM (2002) Cystic fibrosis: a worldwide analysis of CFTR mutations--correlation with incidence data and application to screening. *Hum Mutat* 19:575-606.
- Brown CR, Hong-Brown LQ, Biwersi J, Verkman AS and Welch WJ (1996) Chemical chaperones correct the mutant phenotype of the Δ F508 cystic fibrosis transmembrane conductance regulator protein. *Cell Stress Chaperones* 1:117-125.
- Chen EY, Bartlett MC, Loo TW and Clarke DM (2004) The Δ F508 mutation disrupts packing of the transmembrane segments of the cystic fibrosis transmembrane conductance regulator. *J Biol Chem* 279:39620-39627.
- Cheng SH, Gregory RJ, Marshall J, Paul S, Souza DW, White GA, O'Riordan CR and Smith AE (1990) Defective intracellular transport and processing of CFTR is the molecular basis of most cystic fibrosis. *Cell* 63:827-834.
- Cornet-Boyaka E, Jablonsky M, Naren AP, Jackson PL, Muccio DD and Kirk KL (2004) Rescuing cystic fibrosis transmembrane conductance regulator (CFTR)-processing mutants by transcomplementation. *Proc Natl Acad Sci U S A* 101:8221-8226.

MOL#23994

- Cui L, Aleksandrov LA, Hou YX, Gentsch M, Chen JH, Riordan JR and Aleksandrov AA (2006) The role of cystic fibrosis transmembrane conductance regulator phenylalanine 508 side chain in ion channel gating. *J Physiol* 572:347-358.
- Denning GM, Anderson MP, Amara JF, Marshall J, Smith AE and Welsh MJ (1992) Processing of mutant cystic fibrosis transmembrane conductance regulator is temperature-sensitive. *Nature* 358:761-764.
- Gupta J, Evagelidis A, Hanrahan JW and Linsdell P (2001) Asymmetric structure of the cystic fibrosis transmembrane conductance regulator chloride channel pore suggested by mutagenesis of the twelfth transmembrane region. *Biochemistry* 40:6620-6627.
- Loo TW, Bartlett MC and Clarke DM (2004) Thapsigargin or curcumin does not promote maturation of processing mutants of the ABC transporters, CFTR, and P-glycoprotein. *Biochem Biophys Res Commun* 325:580-585.
- Loo TW, Bartlett MC and Clarke DM (2005) Rescue of Δ F508 and other misprocessed CFTR mutants by a novel quinazoline compound. *Mol Pharm* 2:407-413.
- Loo TW, Bartlett MC, Wang Y and Clarke DM (2006) The chemical chaperone CFcor-325 repairs folding defects in the transmembrane domains of CFTR processing mutants. *Biochem J* 395:537-542.
- Loo TW and Clarke DM (1994) Prolonged association of temperature-sensitive mutants of human P-glycoprotein with calnexin during biogenesis. *J. Biol. Chem.* 269:28683-28689.
- Loo TW and Clarke DM (1995a) P-glycoprotein. Associations between domains and between domains and molecular chaperones. *J Biol Chem* 270:21839-21844.

MOL#23994

Loo TW and Clarke DM (1995b) Rapid purification of human P-glycoprotein mutants expressed transiently in HEK 293 cells by nickel-chelate chromatography and characterization of their drug-stimulated ATPase activities. *J Biol Chem* 270:21449-21452.

Loo TW and Clarke DM (1997) Correction of defective protein kinesis of human P-glycoprotein mutants by substrates and modulators. *J Biol Chem* 272:709-712.

Loo TW and Clarke DM (1999a) The human multidrug resistance P-glycoprotein is inactive when its maturation is inhibited: potential for a role in cancer chemotherapy. *Faseb J* 13:1724-1732.

Loo TW and Clarke DM (1999b) The transmembrane domains of the human multidrug resistance P-glycoprotein are sufficient to mediate drug binding and trafficking to the cell surface. *J Biol Chem* 274:24759-24765.

Loo TW and Clarke DM (2001) Defining the drug-binding site in the human multidrug resistance P-glycoprotein using MTS-verapamil. *J Biol Chem* 276:14972-14979.

Loo TW and Clarke DM (2005a) Recent progress in understanding the mechanism of P-glycoprotein-mediated drug efflux. *J Membr Biol* 206:173-185.

Loo TW and Clarke DM (2005b) Rescue of folding defects in ABC transporters using pharmacological chaperones. *J Bioenerg Biomembr* 37:501-507.

Pedemonte N, Lukacs GL, Du K, Caci E, Zegarra-Moran O, Galiotta LJ and Verkman AS (2005) Small-molecule correctors of defective $\Delta F508$ -CFTR cellular processing identified by high-throughput screening. *J Clin Invest* 115:2564-2571.

Riordan JR, Rommens JM, Kerem B, Alon N, Rozmahel R, Grzelczak Z, Zielenski J, Lok S, Plavsic N, Chou JL, Drumm ML, Iannuzzi MC, Collins FS and Tsui L-C (1989)

MOL#23994

Identification of the cystic fibrosis gene: cloning and characterization of complementary DNA. *Science* 245:1066-1073.

Sato S, Ward CL, Krouse ME, Wine JJ and Kopito RR (1996) Glycerol reverses the misfolding phenotype of the most common cystic fibrosis mutation. *J Biol Chem* 271:635-638.

Van Goor F, Straley KS, Cao D, Gonzalez J, Hadida S, Hazlewood A, Joubran J, Knapp T, Makings LR, Miller M, Neuberger T, Olson E, Panchenko V, Rader J, Singh A, Stack JH, Tung R, Grootenhuis PD and Negulescu P (2006) Rescue of $\Delta F508$ CFTR trafficking and gating in human cystic fibrosis airway primary cultures by small molecules. *Am J Physiol Lung Cell Mol Physiol*:(in press).

Ward CL and Kopito RR (1994) Intracellular turnover of cystic fibrosis transmembrane conductance regulator. Inefficient processing and rapid degradation of wild-type and mutant proteins. *J Biol Chem* 269:25710-25718.

Zhang XM, Wang XT, Yue H, Leung SW, Thibodeau PH, Thomas PJ and Guggino SE (2003) Organic solutes rescue the functional defect in $\Delta F508$ cystic fibrosis transmembrane conductance regulator. *J Biol Chem* 278:51232-51242.

MOL#23994

Footnotes

This work was supported by a grant from the Canadian Institutes of Health Research. DMC is the recipient of the Canada Research Chair in Membrane Biology.

MOL#23994

Legends for Figures

Fig. 1. Structures of pharmacological chaperones and CFTR. A, the structures of CFpot-532 and corr-2b are shown. B, the model of CFTR shows the transmembrane segments as numbered cylinders. The regions that make up the transmembrane domains (TMD) and nucleotide-binding domains (NBD) are shown. The branched lines represent glycosylation sites while R represents the regulatory domain. The positions of processing mutations are indicated.

Fig. 2. Measurement of iodide efflux activity of $\Delta F508$ CFTR after low temperature rescue. Iodide efflux assays were performed on BHK cells stably expressing $\Delta F508$ CFTR that had been incubated at 27 °C for 24 h. Time 0 is the start of stimulation through addition of 10 μ M CFpot-532, forskolin or forskolin and CFpot-532 together.

Fig. 3. Rescue of $\Delta F508$ CFTR with pharmacological chaperones. BHK cells stably expressing $\Delta F508$ CFTR were incubated for 48 h in the presence of 0 - 20 μ M CFpot-532 (A) or in the presence of 10 μ M CFpot-532, CFcor-325 or corr-4b (B). Whole cell extracts were subjected to immunoblot analysis with a rabbit polyclonal (A) or monoclonal (B) antibody against CFTR. In B, samples were treated with endo H (H) or PNGase F (F) prior to immunoblot analysis. The positions of mature (Mature), immature (Immature) and deglycosylated (Unglycos) CFTRs are indicated.

MOL#23994

Fig. 4. Iodide efflux activities of Δ F508 CFTR expressed in the presence or absence of CFpot-532. BHK cells expressing wild-type or Δ F508 CFTR were incubated at 37 °C in the presence or absence of 10 μ M CFpot-532 for 48 h. Time 0 is the start of stimulation through addition of 10 μ M forskolin.

Fig. 5. Effect of pharmacological chaperones on maturation of P-glycoprotein processing mutant G268V. HEK 293 cells were transiently transfected with P-glycoprotein G268V cDNA and then incubated for 24 h in the absence (-) or presence of 10 μ M CFcor-325, CFpot-532, corr-2b, corr-3a, corr-4a, corr-4b or cyclosporin A (Cyclo). Whole cell extracts were then subjected to immunoblot analysis with a polyclonal antibody against P-glycoprotein. The positions of mature and immature P-glycoproteins are shown.

Fig. 6. Effect of pharmacological chaperones on P-glycoprotein ATPase activity. Histidine-tagged wild-type P-glycoprotein was expressed in HEK 293 cells, isolated by nickel-chelate chromatography and mixed with lipid. (A) P-glycoprotein ATPase activity was then measured in the presence or absence of 0.3 mM CFcor-325, CFpot-532, corr-2b, corr-3a, corr-4a or corr-4b. The fold-stimulation is the ratio of ATPase activity in the presence of compound to the ATPase activity in the absence of drug. (B) P-glycoprotein ATPase activity was measured in the presence of 0.3 mM verapamil in the presence or absence (No drug) of 0.3 mM CFcor-325, CFpot-532, corr-2b, corr-3a, corr-4a or corr-4b. The fold-stimulation is the ratio of ATPase activity in the presence of verapamil to the activity in the absence of verapamil.

MOL#23994

Fig. 7. Effect of CFpot-532 on maturation of CFTR with a processing mutation in the COOH-half of the molecule. HEK 293 cells were transiently transfected with CFTR wild-type or H1085R cDNAs and then expressed in the absence (-) or presence (+) of 10 μ M CFpot-532 for 48 h. Whole cell extracts were subjected to immunoblot analysis with a CFTR polyclonal antibody. The positions of mature (Mature) and immature (Immature) CFTRs are indicated.

A

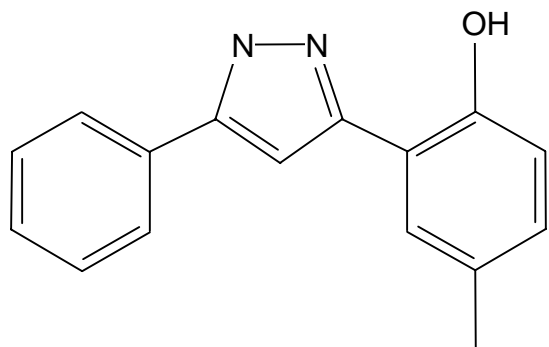

CFpot-532

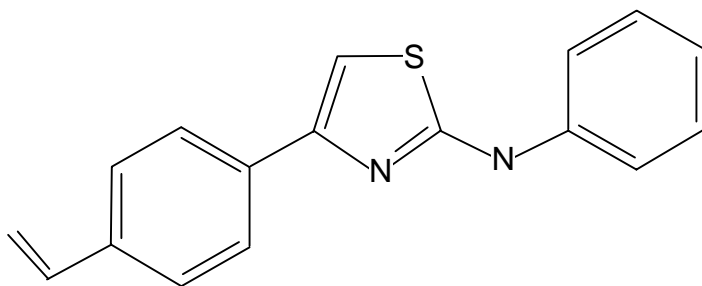

corr-2b

B

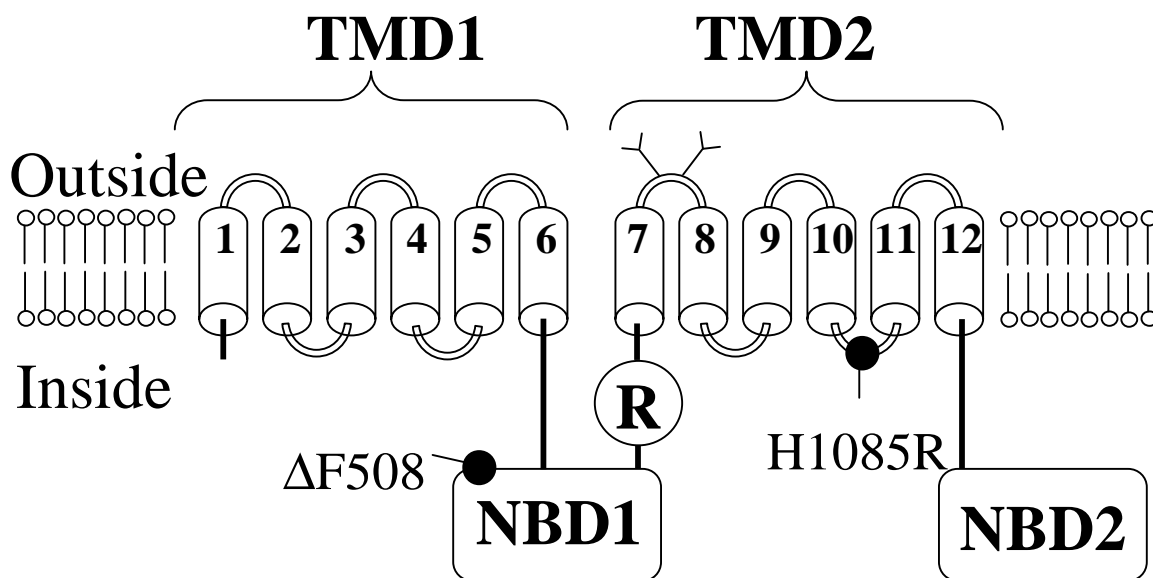

Fig. 1

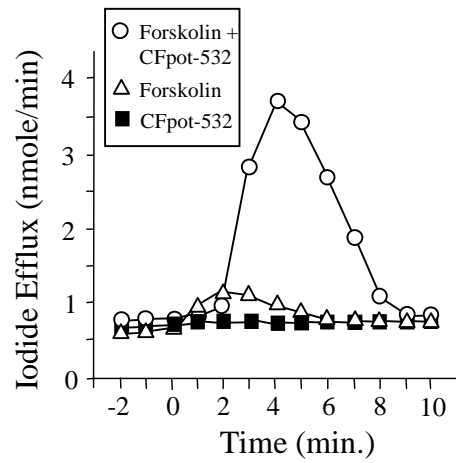

Fig. 2
Wang et al.

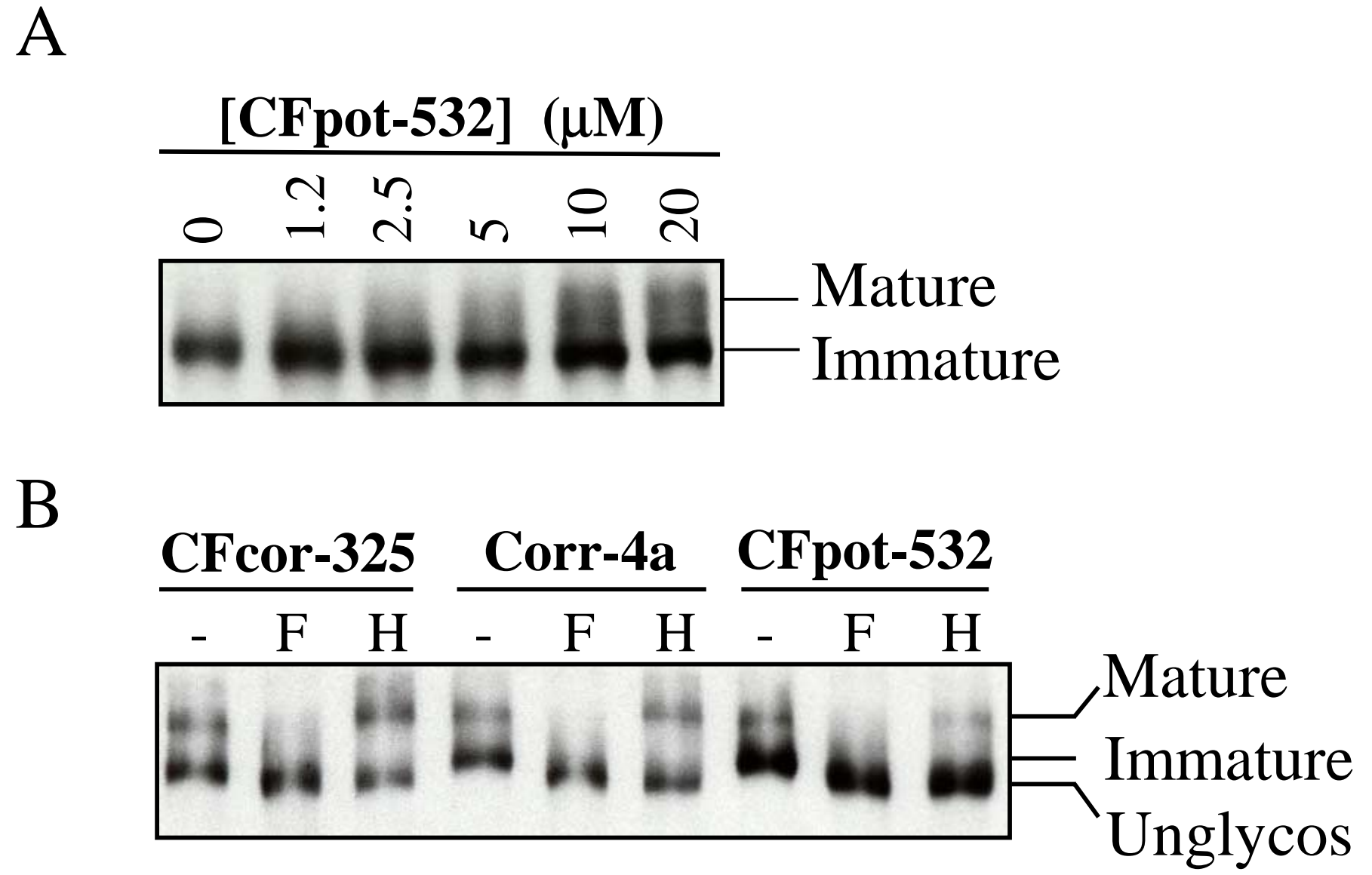

Fig. 3

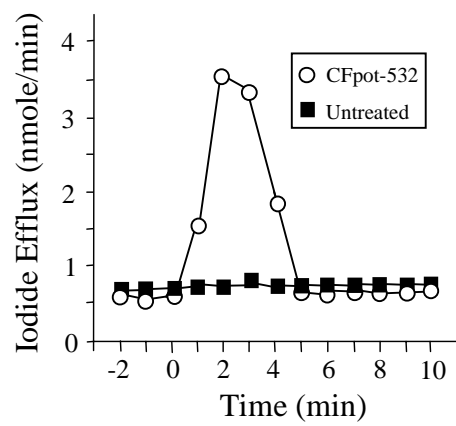

Fig. 4

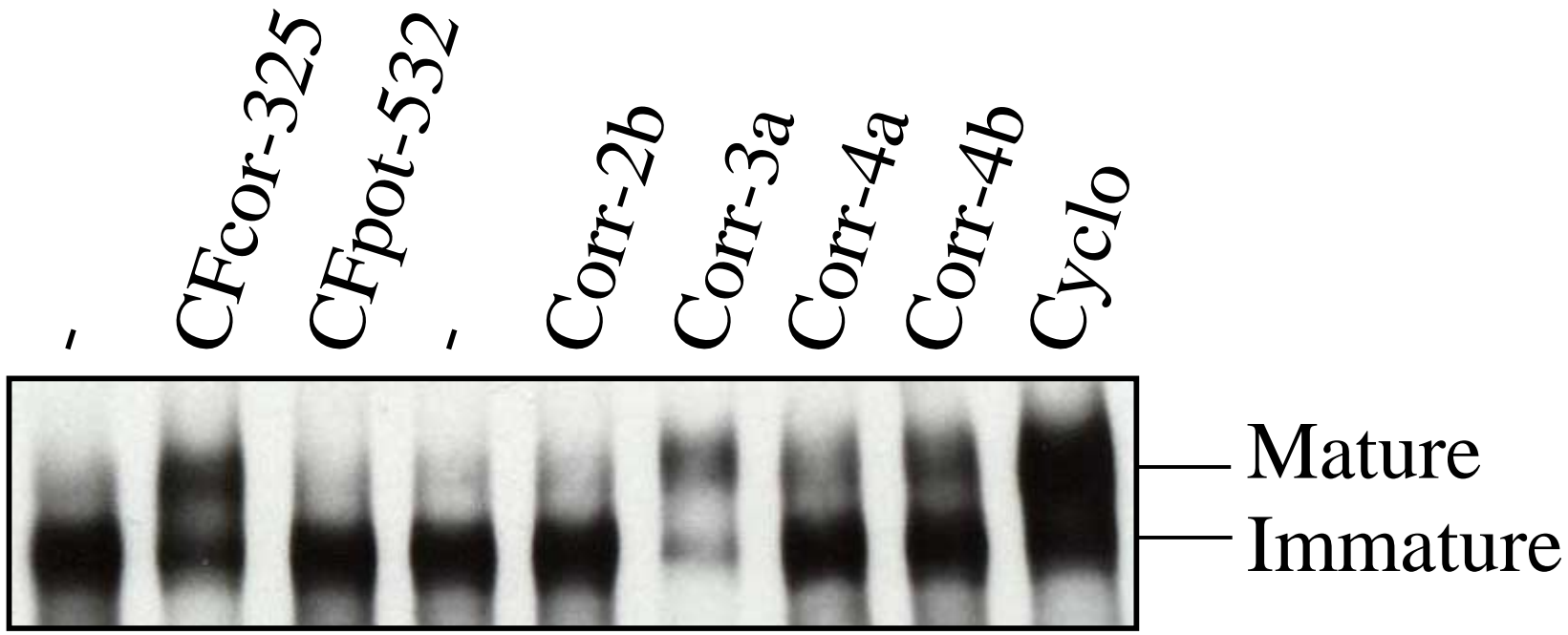
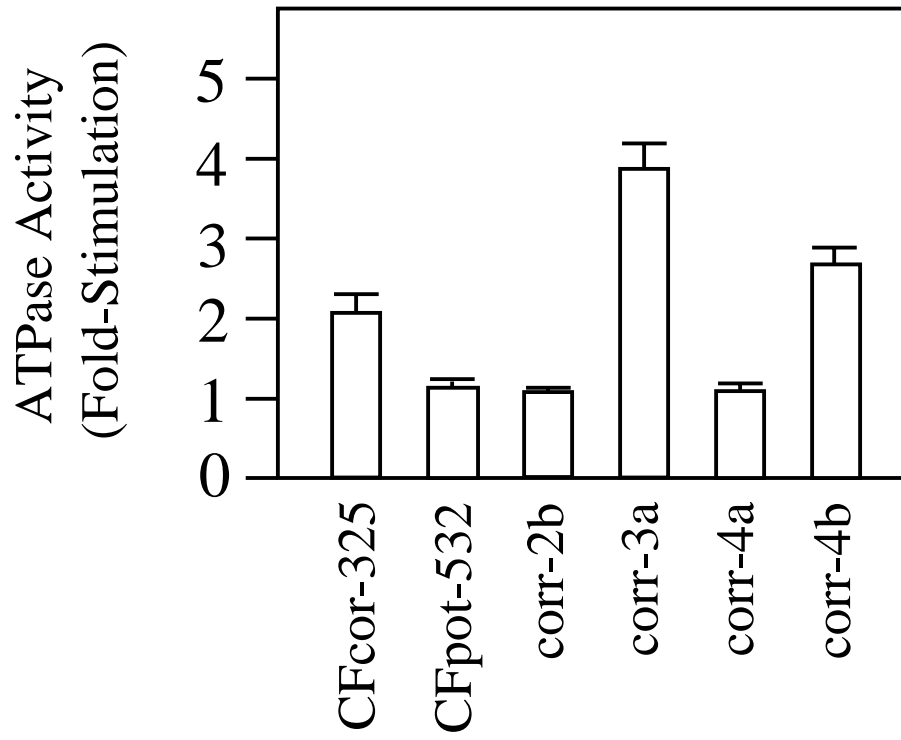

Fig. 5

A



B

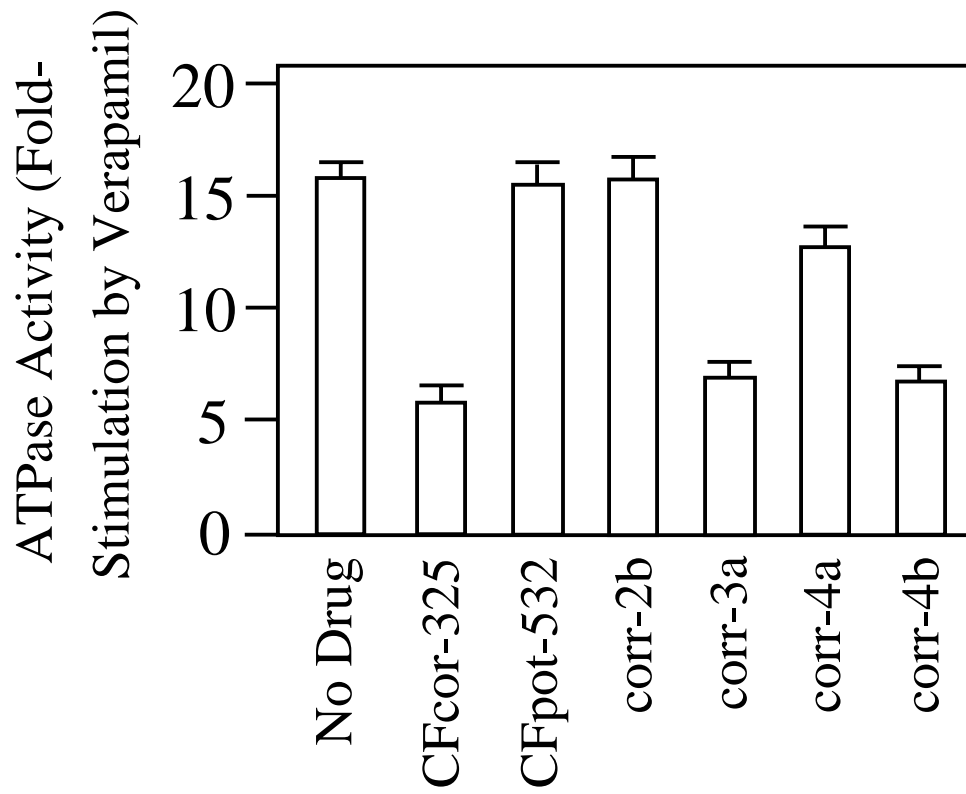

Fig. 6.

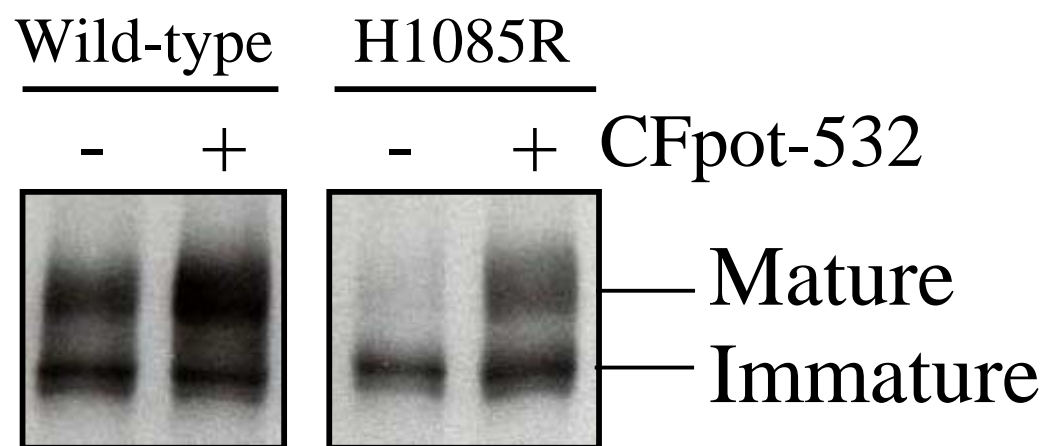

Fig. 7