

TITLE PAGE

**RXR-DEPENDENT TRANSACTIVATION BY A NATURALLY OCCURRING
STRUCTURAL VARIANT OF HUMAN CAR (NR1I3)**

Scott S. Auerbach, Matthew A. Stoner, Shengzhong Su, Curtis J. Omiecinski

Department of Pharmacology (SSA), School of Medicine, University of Washington, Seattle,
Washington 98195

Center for Molecular Toxicology and Carcinogenesis (MAS, SS, CJO), and Department of
Veterinary Science, The Pennsylvania State University, University Park, Pennsylvania 16802

RUNNING TITLE PAGE

Running Title: CAR3 is a ligand activated receptor

Address correspondence to: Curtis J. Omiecinski, Center for Molecular Toxicology and Carcinogenesis,
The Pennsylvania State University, 201 Life Sciences Bldg., University Park, Pennsylvania 16802, Tel.
814-863-1625; Fax. 814-863-1696; E-mail: cjo10@psu.edu.

Number of Text Pages: 19

Number of Tables: 5

Number of Figures: 9

Number of References: 53

Abstract: 247 words

Introduction: 657 words

Discussion: 1460 words

Abbreviations: **AF1**, Activation function 1; **AF2**, Activation function 2; **CAR**, (CAR1, MB67, NR1H3, constitutive androstane receptor); **CITCO**, 6-(4-chlorophenyl)imidazo[2,1-*b*]thiazole-5-carbaldehyde *O*-(3,4-dichlorobenzyl)oxime; **EMSA**, electrophoretic mobility shift assay; **PBREM**, phenobarbital response enhancer module; **PCR**, polymerase chain reaction; **RXR**, retinoid X receptor alpha; **SRC-1**, steroid receptor coactivator-1; **XREM**, xenobiotic-responsive enhancer module.

ABSTRACT

The constitutive androstane receptor, CAR, mediates the hepatic induction of various xenobiotic metabolizing enzymes and transporters following specific chemical exposures. Recent reports have established the existence of several human CAR mRNA splice variants, including a prominently expressed form termed CAR3, a receptor that possesses a 5 amino acid insertion within its ligand binding domain. Here we demonstrate that, in contrast to the constitutively active reference form of the receptor, CAR3 is ligand-activated, transactivating an optimized DR-4X3 reporter in response to the hCAR ligand, CITCO. The transactivation response requires the DNA binding domain and AF-2 motif of CAR3, and is markedly enhanced by RXR cotransfection. The stimulatory effects of RXR involve a unique mechanism as they were completely dependent on the RXR AF-2 function but independent of both the RXR A/B domain and its C domain/ heterodimerization region. Mammalian 2-hybrid results demonstrated that RXR enhanced CITCO-dependent interaction of CAR3 with the receptor interaction domain of SRC-1, indicating that RXR augments CAR3 activity by facilitating coactivator recruitment. Notably, clotrimazole also functions as a ligand activator of CAR3, in contrast to the inverse agonist activity exhibited by this agent on the reference form of the receptor. Further, results of transfection assays reveal that CAR3 is capable of transactivating the natural *CYP2B6* and *CYP3A4* gene enhancers, exhibiting both ligand- and RXR-dependence. These results demonstrate that unlike CAR1, CAR3 is a ligand activated receptor and that CAR3 may regulate gene expression *in vivo* in a manner distinct from the reference form of the receptor.

INTRODUCTION

The constitutive androstane receptor (CAR, MB67, NR1I3) is a member of the nuclear hormone receptor superfamily (Nomenclature Report, 1999). Its expression is most prevalent in the liver where it mediates the induction of drug and endobiotic metabolism through a mechanism involving the direct regulation of genes encoding biotransformation enzymes (Baes *et al.*, 1994; Handschin *et al.*, 2003; Wang and LeCluyse, 2003; Handschin and Meyer, 2003). Studies involving genetically modified mice have demonstrated specific roles for CAR in xenobiotic (Wei *et al.*, 2000; Zhang *et al.*, 2002), heme (Huang *et al.*, 2003; Xie *et al.*, 2003), carcinogen (Xie *et al.*, 2003), bile acid (Assem *et al.*, 2004; Guo *et al.*, 2003; Saini *et al.*, 2004), and thyroid hormone metabolism (Maglich *et al.*, 2004). Furthermore, quantitative trait loci analyses have suggested a role for CAR in HDL homeostasis, an observation that compliments other investigations showing that cholesterol precursors (isoprenoids) regulate CAR activity (Kocarek and Mercer-Haines, 2002; Wang *et al.*, 2003b). Together, these findings imply that CAR-mediated activities are potentially important modifiers of human disease processes such as drug-induced hepatotoxicity, carcinogenesis, cholestasis, atherosclerosis and obesity.

Identified CAR ligands include TCPOBOP (mCAR specific agonist) (Tzamei *et al.*, 2000), 5 β -Pregnane-3,20-dione (hCAR specific agonist) (Moore *et al.*, 2000), CITCO (hCAR agonist) (Maglich *et al.*, 2003), clotrimazole (hCAR specific inverse agonist) (Moore *et al.*, 2000), and androstanol (mCAR inverse agonist) (Forman *et al.*, 1998). Using microarray analyses, a number of CAR-regulated genes have been elucidated (Maglich *et al.*, 2002; Ueda *et al.*, 2002), and many of these genes appear directly involved in the metabolism and transport of xenobiotics, e.g., *CYP2B6* (Sueyoshi *et al.*, 1999; Wang *et al.*, 2003a), *CYP3A4* (Goodwin *et al.*, 2002), *CYP2C9* (Ferguson *et al.*, 2002; Gerbal-Chaloin *et al.*, 2002), *CYP2C19* (Chen *et al.*, 2003), *UGT1A1* (Sugatani *et al.*, 2001) and *MDR1* (Arnold *et al.*, 2004; Geick *et al.*, 2001). Subsequent to inducer treatment *in vivo* or in primary cultures of hepatocytes, CAR translocates to the nucleus, heterodimerizes with RXR and interacts with its target genes (Baes *et al.*, 1994; Honkakoski *et al.*, 1998; Kawamoto *et al.*, 1999). An idealized response element for CAR/RXR has been described as a DR-4 element (direct repeat-4) (Frank *et al.*, 2003), although other functional CAR

response elements have been characterized, including the DR-2, -3, -5, ER (everted repeat)-6, -8 and IR (inverted repeat) -0 format (Handschin and Meyer, 2003). Further, results from this and other investigations (Frank *et al.*, 2003) suggest that CAR is capable interacting with 5'-extended nuclear receptor response elements as a monomer.

Initially, we identified the existence of several CAR splice variants that are expressed concurrently in human liver (Auerbach *et al.*, 2003). These observations have since been substantiated by other laboratories (Jinno *et al.*, 2004; Arnold *et al.*, 2004; Lamba *et al.*, 2004; Savkur *et al.*, 2003). The CAR3 variant in particular, is detected in liver tissues at relatively high levels, levels approaching those of CAR1 in certain individuals (Jinno *et al.*, 2004) and unpublished observations). We have hypothesized that the 5 amino acid insertion present in CAR3, occurring in the highly conserved loop 8-9 of the ligand binding domain, may alter the ligand and DNA binding properties of the variant receptor (Auerbach *et al.*, 2003). Although CAR3 exhibits ligand (CITCO) -dependent coactivator interaction (Arnold *et al.*, 2004), significant transactivation by CAR3 of heterologous reporters has not been observed (Arnold *et al.*, 2004; Jinno *et al.*, 2004; Auerbach *et al.*, 2003). In this investigation, we sought to more critically evaluate the functional properties CAR3. With the use of multiple heterologous reporters, engineered with nuclear receptor half sites paced at 1-5 base pairs, we now demonstrate that CAR3 mediates transactivation of an optimized DR-4 reporter in a ligand-dependent manner and establish that the CAR1 inverse agonist, clotrimazole, functions as a *bone fide* agonist of CAR3. In addition, we report that RXR over expression markedly enhances CAR3-coactivator interactions as well as CAR3 activation of a DR-4X3 reporter. Finally, we demonstrate RXR- and ligand-dependent activation of the endogenous *CYP2B6* and *CYP3A4* reporters by CAR3, supporting a biological function of the variant receptor, *in vivo*.

MATERIALS AND METHODS

Materials. 6-(4-chlorophenyl)imidazo[2,1-b][1,3]thiazole-5-carbaldehyde *O*-(3,4-dichlorobenzyl)oxime (CITCO) were purchased from Biomol (Plymouth Meeting, PA). Clotrimazole and dimethylsulfoxide were obtained from Sigma (St Louis, MO) and EM Science (Gibbstown, NJ),

respectively. Primers for PCR and EMSA were purchased from Integrated DNA Technologies (Coralville, IO).

Plasmids. PCR-based cloning was performed with AccuPOL™ DNA polymerase (GeneChoice, Frederick, MD). All clones were verified by DNA sequencing. Constructs cloned into the expression vectors contained only the protein coding regions, preceded by a Kozak sequence (Kozak, 1987). Mutagenesis was performed using the indicated primers (mt) and the QuikChange® site-directed mutagenesis kit (Stratagene, La Jolla, CA) according to the manufacturer's protocol. Prior to transfection, plasmids were prepped using the Quantum Prep Plasmid Maxiprep Kit (Bio-Rad, Hercules, CA). All RXR clones referred to in this paper are derived from human RXR α . Details of the primers used and design of all of the plasmid constructs used in this study are provided in Tables I-V.

Cell Culture and Transfections. SV40 transformed African green monkey kidney cells, COS-1, and human embryonic kidney, HEK293, were maintained and transfected in Dulbecco's modified Eagle medium with 10% FBS, 2 mM L-glutamine, 10 mM HEPES, 0.15% sodium bicarbonate, 50 units/ml penicillin G and 50 μ g/ml streptomycin (all purchased from Invitrogen Life Technologies, Carlsbad, CA).

All transfections for luciferase reporter assays were performed in a 48-well format. On the morning of day one, cells were plated at a density of 50,000 cells/well. While the cells were attaching DNA transfection mixtures were assembled using the Fugene6 transfection reagent (Roche Applied Science, Indianapolis, IN). In general, for assays involving standard reporters (not 2-hybrid), a combination of 25 ng of CMV2 or CMV2-CAR expression plasmid, 25 ng pcDNA3.1 or 3.1-RXR expression plasmid, 100 ng luciferase reporter and 10 ng of pRL-CMV (for transfection normalization; Promega, Madison, WI) was transfected into each well of a 48-well plate. In one set of experiments, 40 ng virus protein 16 (VP16) or VP16-CAR3 was transfected in combination with 10 ng RXR, 100 ng DR-4X3 luciferase reporter and 10 ng pRL-CMV. All mammalian two-hybrid assays were performed with 40 ng pVP16 expression plasmid, 10 ng pM (GAL4) expression plasmid, 100 ng of pFR-luciferase (luc) reporter and 10 ng pRL-CMV. Where indicated, 10 ng of RXR-pcDNA3.1 expression plasmid was used in the two-hybrid assays. The Fugene6™ transfection reagent was used at a ratio of 1:3 (micrograms of

DNA: microliters of Fugene6TM reagent), as recommended in the manufacturer's protocol. Within a given experiment all transfections contained the same total amount of DNA. At the time of transfection (~6 h post-plating), cells were approximately 80% confluent and had initiated cell division. The following day (16-18 h after transfection), cells were treated with chemical agents as indicated in the figures. If chemical treatment was not performed, cells were lysed and assayed 24 h post-transfection. In treated samples, media levels of DIMETHYLSULFOXIDE levels never exceeded 0.1% [vol/vol]. On day three (24 h after chemical treatment), cells were washed with PBS and luciferase assays were performed using the Dual-LuciferaseTM Reporter Assay System (Promega, Madison, WI) and analyzed with a Veritas Microplate LuminometerTM (Turner Biosystems, Sunnyvale, CA). The luciferase assay and stop & glow reagents were diluted with 1XTBS (Tris Buffer Saline, pH 8.0) to 0.5X concentration. All other aspects of the assay were performed in accordance to the manufacturer's protocol. Dilution of the luciferase reagent had no effect on normalized luciferase values.

For expression studies and for generating EMSA nuclear extracts, 500 ng 3XFLAG-tagged CAR1, CAR3 or 3XFLAG-BAP were cotransfected with 500 ng pcDNA3.1 or 3.1-RXR into a single well of a 6 well plate using the Fugene6TM transfection reagent. For CITCO treatments, the chemical was added 18 h after transfection and cells were incubated for an additional 24 h. If chemical treatment was not performed, e.g. in EMSA studies, cells were harvested 24 h after transfection as detailed below.

Nuclear extraction, western blot and electrophoretic mobility shift assays. Crude nuclear extracts were prepared from individual wells of a 6-well plate that had reached confluence within 24 h of transfection. The protocol has been described in detail elsewhere (Stoner *et al.*, 2002). Briefly, cells were trypsinized and collected following the addition of an equal volume of serum-containing media. Pulse centrifugation was used to collect the cells, which were then washed with 100 pellet volumes of PBS. Cells were resuspended in 10 pellet volumes of 1X reporter lysis buffer (Promega, Madison, WI) containing a protease inhibitor cocktail (Calbiochem, La Jolla, CA) and placed on ice for 30 m to allow for passive lysis of the plasma membrane. Every 5-10 m the samples were vortexed gently and then placed back on ice. Nuclei were subsequently collected by centrifugation and resuspended in 10 pellet

volumes of 1X reporter lysis buffer supplemented with 500 mM KCl and protease inhibitors. Nuclei were placed on ice and allowed to swell and rupture. Intermittent vortexing was performed to facilitate the nuclear lysis. After 30 m on ice nuclear extract was collected and frozen at -80°C.

Western immunoblotting was performed to determine the level of BAP (bacterial alkaline phosphatase) and CAR protein expression from transfected cells. 40 µg of crude nuclear protein from each sample was separated on a 10% denaturing polyacrylamide gel. Following transfer of protein to PDVF the blot was incubated briefly at room temperature in 5% milk in 0.1% Tween 1XTBS (TTBS) for blocking. Flu Antigen (FLAG) (M2)-HRP conjugated monoclonal antibody (1:2000 in blocking buffer; Sigma, St Louis, MO) was incubated with the PDVF membrane at room temperature for 1 h. The membrane was washed extensively in 1XTTBS, covered with Lumi-Light Western Blotting Substrate (Roche, Indianapolis, IN) and exposed to film.

EMSA were performed as described previously with slight variation (Stoner *et al.*, 2002). 10 pmol of a double stranded DNA probe containing a single copy of the DR-4 response element was end-labeled with T4 kinase and [γ -³²P]-ATP. A 20 µl binding reaction was assembled containing a final concentration of 100 mM KCl (a mixture of low salt and high salt nuclear extract lysis buffers), 6 µg of crude nuclear protein, 1µg dI-dC, 5 µM CITCO or corresponding amount of dimethylsulfoxide, and 20 fmol of labeled probe. Binding reactions were incubated for 15 m at room temperature. Following incubation, where indicated, 1 µg of polyclonal FLAG antibody was added. Antibody/epitope interactions took place at room temperature over 15 m. Protein/DNA complexes were separated on a 5% TBE gel. Gels were dried and exposed to film to visualize mobility shifts.

Statistical analysis. All quantitative data were examined by analysis of variance. Significance was declared if $P < 0.01$. Data are expressed as means \pm SE ($n = 4$).

RESULTS

CAR3 transactivates DR-4X3 and DR5X3 luciferase reporters in a ligand-regulated and RXR-dependent manner. Others have reported a ligand-regulated recruitment of SRC-1 to CAR3

(Arnold *et al.*, 2004), however transactivation by this receptor has not been demonstrated previously. We hypothesized that the inserted amino acids in CAR3 produce a unique receptor with a different spectrum of effects on various DNA response elements. To test this hypothesis, heterologous reporters were constructed that contained 6 copies of an AGTTCA nuclear receptor half site separated by 1 to 5 base pairs. AGTTCA was chosen over AGGTCA since it was demonstrated that CAR1 prefers binding to this half site (Frank *et al.*, 2003). Furthermore, the reporters were engineered to allow preferential interaction with CAR/RXR heterodimers (as opposed to CAR monomers) by placing a GC or TC sequence immediately 5' of each half site (Frank *et al.*, 2003). In absence of cotransfected RXR, CAR3 activated the DR-4X3 reporter only when treated with CITCO (Fig.1A). However, when CAR3 and RXR were cotransfected, enhanced basal levels of activation together with an overall higher ligand-dependent activation of the DR-4X3 reporter were evident, as was a significant ligand-dependent transactivation of the DR-5X3 reporter (Fig. 1A and 1B). CAR1 did not respond to 5 μ M CITCO in our reporter system in the absence of RXR, and surprisingly, was deactivated by CITCO when RXR was cotransfected. As observed with CAR3, RXR cotransfection similarly facilitated a significant transactivation of CAR1 on the DR-2, DR-3 and DR-5 reporters, an effect that was not observed in the absence of cotransfected RXR.

A CITCO dose-response study was performed using the DR-4X3 reporter to assess the effect of RXR on ligand-induced CAR3 activity (Fig. 1C). Transfection of RXR alone had no effect on the reporter. CAR3 transfection in the absence of RXR led to a maximum 6-fold activation, with an estimated EC50 of 1 μ M. Cotransfection of both receptors resulted in a 4-fold increase in basal activity and a maximal CITCO activation of 14-fold. In addition, the estimated EC50 (based on the adjusted basal activity) was decreased approximately 50-fold, to 20 nM CITCO.

CAR3 does not interact with RXR in EMSA or two-hybrid analyses. Previously, electrophoretic mobility shift assays (EMSA) were not capable of demonstrating an RXR-dependent interaction of CAR3 with a CAR response element (Arnold *et al.*, 2004;Auerbach *et al.*, 2003). These prior assays were performed using purified GST-CAR3 and GST-RXR fusion proteins or CAR3 and RXR expressed from reticulocyte lysates. A potential explanation for these observations may involve the

lack of expression of an unknown cofactor protein in COS-1 cells that may otherwise function to facilitate DNA-CAR3/RXR interactions. Furthermore, interaction with such a cofactor might be effected by ligand, as is the case with RXR homodimers and SRC-1 (Ijpenberg *et al.*, 2004). To evaluate this scenario, FLAG-tagged CAR1 and CAR3 expression vectors were cotransfected into COS-1 cells in combination with empty pcDNA3.1 or RXR expression plasmid. A FLAG-tagged bacterial alkaline phosphatase (BAP) expression vector was also transfected as a negative control for DNA binding. Crude nuclear extracts were prepared from the cells 24 h post-transfection. A western blot of 40 μ g nuclear extract was performed to evaluate expression of BAP, CAR1 and CAR3 in these extracts (Fig. 2A). RXR expression did not impact the detectable levels of either CAR1 or CAR3. EMSAs were performed with 6 μ g of the protein extracts. A CAR1 complex is apparent in the absence and presence of CITCO and is further enhanced by cotransfection of RXR. The CAR1 complex was also supershifted following the addition of FLAG antibody (Fig. 2B). In contrast, a CAR3-containing DNA complex could not be detected (Fig. 2B).

Recently, others reported that CAR3 was unable to interact with RXR in mammalian 2-hybrid analysis (Arnold *et al.*, 2004). We performed a similar set of experiments that are presented in Fig. 2C. Although a clear interaction between the LBDs of CAR1 and RXR was evident, a comparable interaction of CAR3 with the RXR was not detected. Neither CITCO treatment nor cotransfection of VP16-SRC-1(RID) was capable of facilitating a CAR3/RXR two-hybrid interaction (data not shown). These results both confirm and extend the results of Arnold *et al.* (Arnold *et al.*, 2004).

Activation of DR-4X3 by CAR3 is dependent on its DNA binding domain and AF-2 domains. Considering that a CAR3 complex was not observed in the EMSA, we questioned whether CAR3 might interact with the reporter directly. A direct interaction would likely be mediated through the DNA binding domain of the receptor. Deletion of DNA binding domain sequences ablated the CAR3-mediated transactivation of the DR-4X3 reporter (Fig. 3), indicating that a CAR3 DNA interaction was important for receptor transactivation. We further reasoned that if the ligand-mediated transactivation occurs *via* the ligand binding domain of CAR3, then deletion of the AF-2 domain of the receptor should block the recruitment of coactivators and hence CAR3's ability to transactivate transcription. Deletion of

the CAR3 AF-2 led to a complete loss of ligand-mediated transactivation (Fig. 3). These data provide support for a mechanism of ligand-dependent activation by CAR3 involving receptor recruitment to DNA *via* its DNA binding domain, with the subsequent recruitment of transcriptional coactivators.

Transfection of RXR has no effect on CAR3 cellular localization. In hepatocytes, CAR1 activity is controlled in part by its cellular localization (Zelko and Negishi, 2000). Furthermore, the CAR interacting protein, GRIP-1, leads to accumulation of CAR in the nucleus independent of ligand treatment (Min *et al.*, 2002). Hence, we considered whether the mechanism of RXR activation of CAR3 might involve an RXR-driven nuclear accumulation of CAR3. Nuclear and cytosolic extracts were generated from transfected COS-1 cells and subjected to western immunoblot analysis. However, the results demonstrated that the relative nuclear/cytosolic distribution of CAR3 was unchanged either by CITCO treatment or by RXR over expression (Fig. 4A).

VP16 possesses a strong nuclear localization sequence in addition to a robust transactivation domain. Therefore, a VP16-CAR3 fusion construct should force nuclear accumulation of the receptor. Although the western blot data of Fig. 4A argue otherwise, if RXR is functioning to enhance CAR3's activity by facilitating the receptor's nuclear accumulation, then fusion of CAR3 receptor with VP16 should serve to eliminate its RXR dependence. In Fig. 4B, we present the results of experiments designed to assess the activity of VP16-CAR3 on the DR-4X3 reporter. Transfection of VP16-CAR3 had no effect on DR-4X3 reporter activity in the absence of CITCO, whereas its presence stimulated reporter activity 10-fold. Co-transfection of RXR led to a 10-fold activation of the reporter in the absence of CITCO treatment. Although these results were striking in themselves, cotransfection of RXR in combination with the CITCO ligand resulted in a synergistic 170-fold transactivation. VP16-CAR1 activity also was enhanced by cotransfection of RXR, although the effect was not as dramatic as that observed with CAR3.

To demonstrate directly the nuclear localization of transfected VP16-CAR3, COS-1 cells were co-transfected with a CAR3-VP16 fusion construct, or a VP16 control vector, and with CMV2/RXR. As shown in Fig. 4C, CAR3 expression clearly co-localized with DAPI nuclear fluorescence in the transfected cells. Together, these results support a mechanism involving RXR activation of CAR3

subsequent to its nuclear translocation, rather than a RXR-directed facilitation of CAR3 nuclear localization.

The AF-2 of RXR is essential for enhancement of CAR3 activity. Recently, a mutagenized form of RXR (Y397A) was described that is heterodimerization deficient (Vivat-Hannah *et al.*, 2003). If, as a means of enhancing CAR3 activity, CAR3 forms heterodimeric complexes with RXR on the DR-4X3 reporter, then cotransfection of the dimerization mutant Y397A should not result in any enhancement of CAR3 activity. When we conducted these assays, we found that the Y397A mutant had the same enhancing effect on CAR3 as the reference form of RXR (Fig. 5), whereas the Y397A RXR mutant was not active in stimulating CAR1 constitutive or ligand-inducible activation (data not shown). These data support a non-classical, dimerization-independent mechanism of RXR-CAR3 activation; a concept that is also supported by additional results from other transfection studies and mammalian 2-hybrid analyses, as described below.

It is well-established that the DNA binding domain of RXR is essential for the interaction of heterodimeric receptor complexes with DNA. If RXR is forming a heterodimeric DNA complex with CAR3, then transfection of an expression construct containing solely the sequences of RXR's ligand binding domain would not be expected to enhance CAR3 activity. However, transfection of the RXR-ligand binding domain alone resulted in similarly enhanced activities as provided by the full length receptor (Fig. 5). It is also well accepted that the RXR AF-2 motif is essential for ligand-regulated interaction of coregulators. If the association of RXR with coregulators is essential for enhancing CAR3 activity, then the deletion of this sequence would be predicted to ablate RXR's enhancing effect. Consistent with this view, transfection of an AF-2-deleted form of RXR was completely ineffective in contributing any stimulation of ligand-independent or -dependent transactivation, indicating that RXR's association with coregulatory factors is mechanistically essential to its CAR3-enhancing activity (Fig. 5). Notably, transfection of an AF-1 domain-deleted RXR was still capable of enhancing CAR3 activity, lending additional support to the importance of an AF-2-dependent recruitment mechanism.

Ligand-dependent CAR3 interaction with SRC-1 is enhanced by RXR. It was previously established that CAR3 recruits SRC-1 and other coactivators in response to CITCO (Arnold *et al.*, 2004). In order to evaluate RXR's effect on ligand-induced recruitment of coactivators, a mammalian 2-hybrid assay was developed where the receptor interaction domain (RID) of SRC-1 was fused to a GAL4 DNA binding domain, and where CAR3 was fused to VP16. If the two fusion proteins interact in the transfected cells then VP16 is recruited to the reporter, leading to increased luciferase expression. As shown in Fig. 6, CITCO additions resulted in a dose-dependent increase in the interaction between CAR3 and SRC-1. Cotransfection of RXR raised the maximum ligand induced interaction between the CAR3 and SRC-1. However, unlike the results obtained in the DR-4X3 reporter assays, RXR did not affect ligand sensitivity (EC₅₀ ~2 μM, +/- RXR) and did not enhance basal activity at low levels of ligand. In addition to SRC-1, we evaluated a number of other nuclear receptor coactivators with respect to their interaction with CAR3, including SRC-2,-3, CBASE PAIRS, p300, PGC-1α, and DRIP205. RXR cotransfection resulted in enhanced CAR3 interactions with each of the coactivators tested (results not shown).

Clotrimazole produces a dose-dependent activation of CAR3 that is enhanced by cotransfection of RXR. By establishing an assay system to allow testing of CAR3 activity it was now possible to evaluate the effect of potential ligands. Initial studies involving known CAR ligands demonstrated an activation of CAR3 by clotrimazole. Clotrimazole is an inverse agonist of CAR1 (Moore *et al.*, 2000). Dose-response experiments using the DR4X3 reporter demonstrated an EC₅₀ of approximately 300 nM when RXR was cotransfected with CAR3, and an EC₅₀ > 3 μM in the absence of RXR (Fig. 7A). To further verify that clotrimazole is acting as a ligand activator of CAR3, mammalian 2-hybrid studies were performed. In these assays, clotrimazole produced a dose-dependent increase in the interaction of CAR3 with the RID of SRC-1. RXR enhanced the maximal interaction with SRC-1. It was not possible to determine if the EC₅₀ was affected due to a lack of a clear plateau in the activation curve (Fig. 7B). Two-hybrid assays were also performed where the CAR3 ligand binding domain was fused to GAL4 and the GAL4-CAR3-ligand binding domain construct was cotransfected with VP16-SRC-1/RID. Treatment of the transfections with CITCO or clotrimazole produced a significant activation of the

GAL4-UAS reporter response. The ligand-dependent activation by GAL4-CAR3-ligand binding domain was enhanced by addition of RXR (Fig. 7C). The augmentation of CAR3 activity by RXR in this assay further supports a mechanism of enhancement by RXR that is independent of CAR3's interaction with DNA.

Clotrimazole and CITCO activate the DR-4X3 reporter in HEK293 cells. To verify that the ligand effects on CAR3 were not cell-type dependent, DR-4X3 reporter assays were performed using HEK293 cells. Both CITCO and clotrimazole enhanced CAR3-dependent transactivation of the reporter in these cells (Fig 8). Notably, the absolute activation by clotrimazole was even higher than CITCO in this cell line.

Ligand and RXR-dependent CAR3-mediated transactivation of CYP2B6 and CYP3A4 reporters. The DR-4X3 reporter employed in the studies described above contains 3 copies of an optimal CAR response element (Frank *et al.*, 2003), a situation that does not exist in the human genome. Hence, studies were undertaken to determine if CAR3 was capable of activating two different luciferase reporters derived from sequences present in the endogenous *CYP2B6* and *CYP3A4* promoters that contain the naturally occurring/degenerate nuclear receptor response elements. The *CYP2B6* promoter contains two regions that confer CAR-mediated activation, the PBREM (Sueyoshi *et al.*, 1999) and XREM (Wang *et al.*, 2003a). The *CYP3A4* promoter also contains two distantly spaced promoter regions that confer xenobiotic inducibility and interact with CAR (Goodwin *et al.*, 2002). These regions are referred to as the proximal ER6 (Barwick *et al.*, 1996) and the XREM, respectively (Goodwin *et al.*, 1999). As described in "Experimental Procedures," both of the *CYP2B6* and *CYP3A4* reporters we used possessed single copies of these promoter regions and were arrayed directly upstream of TK-luciferase. The data generated using the *CYP2B6* and *CYP3A4* reporters are presented in Fig. 9A and 9B, respectively. Transfection of CAR3 in the absence of RXR resulted in no basal or ligand-induced (CITCO or clotrimazole) activity on either the *CYP2B6* or *CYP3A4* promoter. However, cotransfection of CAR3 and RXR yielded a statistically significant CITCO-dependent activation of these reporters. Activation by clotrimazole was only attainable with the *CYP2B6* reporter when RXR was cotransfected. Notably, the constitutive activity of CAR1 on

the *CYP2B6* and *CYP3A4* reporters was enhanced by the cotransfection of RXR. CITCO additions did not significantly activate CAR1, in the absence or presence of RXR on either reporter, although CTICO did down-regulate activity of the receptor on the *CYP2B6* reporter when RXR was cotransfected. Perhaps the most remarkable result of these experiments is the opposite effects of clotrimazole on the activity of CAR1 and CAR3. In all cases, clotrimazole treatments decreased CAR1 activity, while producing an RXR-dependent induction of CAR3 on the *CYP2B6* reporter.

DISCUSSION

CAR3 is a structural variant of the constitutive androstane receptor derived from alternative splicing of the human CAR mRNA. An alternative splice acceptor site in intron 7 inserts 15 nucleotides in the mRNA sequence that in turn leads to an insertion of 5 amino acids in loop 8/9 of the ligand binding domain (Auerbach *et al.*, 2003). Homology modeling studies indicate that the ligand binding pocket of CAR3 and CAR1 are identical (Auerbach *et al.*, 2003). Hence, both receptors would be predicted to interact with the same ligands. The CAR3 splice variant is detected in liver tissues at relatively high levels, levels approaching those of CAR1 in certain individuals (Jinno *et al.*, 2004); and unpublished observations). In contrast to the constitutively active reference form of the receptor, CAR1, the studies presented here demonstrate for the first time that CAR3 possesses unique biological properties, functioning as a ligand-dependent transactivator of both *CYP2B6* and *CYP3A4* reporters, with the 5 amino acid enlargement of loop 8/9 responsible for transforming the reference receptor from one that is normally deactivated by clotrimazole to one that is ligand activated. We also demonstrate that the dependency of the CAR3 transactivation response on RXR cotransfection, an effect that is associated with CAR3 recruitment of transcriptional coactivators, such as SRC-1. Notably, the functional interplay between RXR and CAR3 takes place apparently in the absence of a classical heterodimerization interaction between the receptors. Together, these results demonstrate that CAR3 has acquired the novel property of being a ligand-activated nuclear receptor and further imply that CAR3 may possess unique capabilities as a regulator of gene expression *in vivo*.

With the exception of a monomeric complex formed between purified GST-CAR3 and the *CYP2B6* NR2 element, all efforts to detect a CAR3/DNA complex *in vitro* have been unsuccessful (Auerbach *et al.*, 2003; Arnold *et al.*, 2004). Therefore, the precise mechanisms that account for the marked CAR3 activation effects in co-transfection assay systems remain to be clarified. Intuitively, the evidence presented in this study suggests a direct interaction between the DNA binding domain of CAR3 with selective DNA elements residing in the reporter constructs. Deletion of the CAR3 DNA binding domain disrupts its ability to transactivate a DR-4X3 reporter, and CAR3 itself does not transactivate an

empty TK-luciferase reporter. These results support a proposal that, when expressed in the cell, CAR3 interacts with nuclear receptor half sites *via* its DNA binding domain. EMSA data presented in an earlier manuscript (Auerbach *et al.*, 2003) indicated that a monomeric complex may be the primary means of CAR3 binding to DNA. At first glance, this interpretation appears reasonable, especially in light of another report showing that CAR1 can bind certain DNA sequences in monomeric fashion (Frank *et al.*, 2003). However, the results presented within the current study suggest a more complex scenario. If CAR3 interacts with DNA as a monomer, then spacing of the nuclear receptor half sites in the direct repeat reporters should not affect the capability of CAR3 to transactivate. In fact, we observe the opposite; CAR3 strikingly transactivates the DR-4 reporter with only limited activation of other DR reporters. Initially we designed the DR-4X3 reporter to specifically promote interaction with CAR monomers, by including 3 nuclear receptor half sites, each separated by 12 base pairs, with the dinucleotide AG placed 5' in each half site to facilitate CAR monomer binding (Frank *et al.*, 2003). Although CAR1 produced a weak transactivation of this reporter in the absence of cotransfected RXR, CAR3 did not. Even with the addition of RXR to the transfection mix, CAR3 still only weakly activated the reporter (unpublished results). These data strongly suggest that CAR3 is interacting with DNA as a heterodimeric complex, and considering the predicted disruption of the dimerization interface produced by the CAR3 5 amino acid insertion within a conserved region of this domain, formation of a typical stable dimeric complex between CAR3 and RXR in solution appears unlikely. This view is further supported by the results obtained from our mammalian 2-hybrid experiments. One may consider that dimerization may be possible *via* regions of the dimer interface that remain intact, or through the DNA binding domain (Khorasanizadeh and Rastinejad, 2001), however, the latter scenario is not supported by our results showing the expendable nature of the RXR DNA binding domain in enhancing CAR3's activity. Similarly, if CAR and RXR were interacting through their respective AF-2 motifs, as was proposed for RXR tetramers (Egea *et al.*, 2001), then AF-2-mediated recruitment of coactivators would likely be adversely affected.

We further considered whether detection of dimer formation may be dependent on the presence of additional factors that stabilize the complex; for example, in EMSA studies, RXR homodimers do not

form stable complexes on DR-1 PPREs in the absence of coactivator and ligand (Ijpenberg *et al.*, 2004). However, our EMSA experiments were performed with standard nuclear extract preparations, methods that others have used successfully to demonstrate cofactor interactions, such as SRC-1. We also performed these assays in the presence and absence of the CITCO ligand. We further performed 2-hybrid experiments using the combination of GAL4-RXR, VP16-CAR3 and VP16-SRC1/RID, anticipating that SRC-1 would stabilize the CAR/RXR complex; however, no interaction between CAR3 and RXR was observed (unpublished results). To better account for our results, we note that standard EMSA assays may not accurately reproduce the chromatin context in which protein/DNA interactions take place *in vivo*, a context that can be an important determinant of *bone fide* nuclear receptor-DNA complexation (Urnov and Wolffe, 2001). We suggest that chromatin interactions ultimately determine the nature of CAR3-DNA interactions. A compelling observation that addresses the issue of CAR3-DNA interaction relates to our demonstration of the highly selective and potent transactivation of a DR4X3 reporter by CAR3. This result supports a dynamic model of CAR3-DNA interaction, involving transient formation of CAR3/RXR dimers, with the DNA interaction of the complex mediated principally through the DNA binding domain of CAR3. We speculate that DNA binding provides for a limited enhancement of heterodimeric complex stability. This model may account for the necessity of RXR over-expression for CAR3 activities since high levels of RXR would be expected to drive the formation of RXR heterodimers, especially in the presence of high levels of transfected CAR3.

Our observations are also consistent with a second mechanism whereby RXR may affect CAR3 activity, a mechanism involving the facilitation of ligand-dependent coactivator recruitment to CAR3. In our 2-hybrid experiments, RXR augmented the ligand dependent interaction of CAR3 with SRC-1. Previously, others demonstrated that CAR's interaction with SRC-1 was enhanced by RXR (Dussault *et al.*, 2002). In these latter studies it was assumed that the enhancement of coactivator recruitment was dependent on CAR-RXR heterodimerization and that the associated allosteric effect of RXR was independent of RXR interaction with coactivator (Dussault *et al.*, 2002). Here, we demonstrate that RXR's AF-2 domain is necessary for enhancing CAR3 activity, indicating that coactivator interaction

with RXR is a critical component of the CAR3 activation complex. We hypothesize that RXR competes for a ligand-oblivious corepressor that mimics a coactivator, such as *hairless* (Moraitis *et al.*, 2002) or RIP140 (Treuter *et al.*, 1998), thereby preventing competition with coactivators at CAR3's coregulator binding cleft (Steinmetz *et al.*, 2001). Such a model would appear to reconcile the noted CAR3/RXR dimerization deficiencies. Further, squelching of a ligand-oblivious corepressor may explain the consistently lower activity of CAR3 in the absence of RXR, even at saturating ligand levels. Although additional studies are necessary to evaluate these potential mechanisms, our results clearly show that RXR over-expression greatly enhances SRC-1 interaction with CAR3.

The activation of the *CYP2B6* and *CYP3A4* gene reporters by CAR3 lends additional credibility to the proposal that this receptor variant is likely a *bona fide* regulator of these genes *in vivo*. Our results demonstrated a relatively weak, ~12-fold activation of the *CYP2B6* reporter by CAR1 in the absence of RXR, whereas in its presence, nearly a 60-fold activation was observed. In the context of a human hepatocyte, phenobarbital induction responses for the *CYP2B6* gene range between 30-70 fold (Faucette *et al.*, 2004), an induction level that otherwise parallels that obtained in our RXR cotransfection experiments. Further, in human hepatocytes, 100 nM CITCO is sufficient to produce a robust induction of CAR target genes (Maglich *et al.*, 2003). In the presence of cotransfected RXR, 50 to 500 nM CITCO markedly activates our CAR3 reporter, supporting the idea that CAR3 may at least partially mediate CITCO's effect on gene transcription. Faucette *et al.* note an induction of *CYP2B6* expression by clotrimazole between 1 and 10 μ M, approximating the dose response data exhibited in our CAR3 studies using a DR4X3 element as well as the dose range observed for clotrimazole's CAR3-dependent transactivation of the *CYP2B6* reporter (Faucette *et al.*, 2004). Additional analyses probing the *in vivo* relevance of CAR3 expression may require extended studies of humanized CAR3 mice, studies that are underway in our laboratory.

Acknowledgements

The authors would like to thank Denise Weyant for expert technical assistance and Jack Vanden Heuvel and Eric Tien for gifts of plasmids and suggestions regarding the mammalian 2-hybrid assays.

REFERENCES

- Arnold KA, Eichelbaum M and Burk O (2004) Alternative Splicing Affects the Function and Tissue-Specific Expression of the Human Constitutive Androstane Receptor. *Nucl Recept* **2**: pp 1.
- Assem M, Schuetz E G, Leggas M, Sun D, Yasuda K, Reid G, Zelcer N, Adachi M, Strom S, Evans R M, Moore D D, Borst P and Schuetz J D (2004) Interactions Between Hepatic Mrp4 and Sult2a As Revealed by the Constitutive Androstane Receptor and Mrp4 Knockout Mice. *J Biol Chem* **279**: pp 22250-22257.
- Auerbach SS, Ramsden R, Stoner M A, Verlinde C, Hassett C and Omiecinski C J (2003) Alternatively Spliced Isoforms of the Human Constitutive Androstane Receptor. *Nucleic Acids Res* **31**: pp 3194-3207.
- Baes M, Gulick T, Choi H S, Martinoli M G, Simha D and Moore D D (1994) A New Orphan Member of the Nuclear Hormone Receptor Superfamily That Interacts With a Subset of Retinoic Acid Response Elements. *Mol Cell Biol* **14**: pp 1544-1551.
- Barwick JL, Quattrochi L C, Mills A S, Potenza C, Tukey R H and Guzelian P S (1996) Trans-Species Gene Transfer for Analysis of Glucocorticoid-Inducible Transcriptional Activation of Transiently Expressed Human CYP3A4 and Rabbit CYP3A6 in Primary Cultures of Adult Rat and Rabbit Hepatocytes. *Mol Pharmacol* **50**: pp 10-16.
- Chen Y, Ferguson S S, Negishi M and Goldstein J A (2003) Identification of Constitutive Androstane Receptor and Glucocorticoid Receptor Binding Sites in the CYP2C19 Promoter. *Mol Pharmacol* **64**: pp 316-324.
- Dussault I, Lin M, Hollister K, Fan M, Termini J, Sherman M A and Forman B M (2002) A Structural Model of the Constitutive Androstane Receptor Defines Novel Interactions That Mediate Ligand-Independent Activity. *Mol Cell Biol* **22**: pp 5270-5280.

Egea PF, Rochel N, Birck C, Vachette P, Timmins P A and Moras D (2001) Effects of Ligand Binding on the Association Properties and Conformation in Solution of Retinoic Acid Receptors RXR and RAR. *J Mol Biol* **307**: pp 557-576.

Faucette SR, Wang H, Hamilton G A, Jolley S L, Gilbert D, Lindley C, Yan B, Negishi M and LeCluyse E L (2004) Regulation of CYP2B6 in Primary Human Hepatocytes by Prototypical Inducers. *Drug Metab Dispos* **32**: pp 348-358.

Ferguson SS, LeCluyse E L, Negishi M and Goldstein J A (2002) Regulation of Human CYP2C9 by the Constitutive Androstane Receptor: Discovery of a New Distal Binding Site. *Mol Pharmacol* **62**: pp 737-746.

Forman BM, Tzameli I, Choi H S, Chen J, Simha D, Seol W, Evans R M and Moore D D (1998) Androstane Metabolites Bind to and Deactivate the Nuclear Receptor CAR- Beta. *Nature* **395**: pp 612-615.

Frank C, Gonzalez M M, Oinonen C, Dunlop T W and Carlberg C (2003) Characterization of DNA Complexes Formed by the Nuclear Receptor Constitutive Androstane Receptor. *J Biol Chem* **278**: pp 43299-43310.

Geick A, Eichelbaum M and Burk O (2001) Nuclear Receptor Response Elements Mediate Induction of Intestinal MDR1 by Rifampin. *J Biol Chem* **276**: pp 14581-14587.

Gerbai-Chaloin S, Daujat M, Pascussi J M, Pichard-Garcia L, Vilarem M J and Maurel P (2002) Transcriptional Regulation of CYP2C9 Gene. Role of Glucocorticoid Receptor and Constitutive Androstane Receptor. *J Biol Chem* **277**: pp 209-217.

Goodwin B, Hodgson E, D'Costa D J, Robertson G R and Liddle C (2002) Transcriptional Regulation of the Human CYP3A4 Gene by the Constitutive Androstane Receptor. *Mol Pharmacol* **62**: pp 359-365.

Goodwin B, Hodgson E and Liddle C (1999) The Orphan Human Pregnane X Receptor Mediates the Transcriptional Activation of CYP3A4 by Rifampicin Through a Distal Enhancer Module. *Mol Pharmacol* **56**: pp 1329-1339.

Guo GL, Lambert G, Negishi M, Ward J M, Brewer H B, Jr., Kliewer S A, Gonzalez F J and Sinal C J (2003) Complementary Roles of Farnesoid X Receptor, Pregnane X Receptor, and Constitutive Androstane Receptor in Protection Against Bile Acid Toxicity. *J Biol Chem* **278**: pp 45062-45071.

Handschin C and Meyer U A (2003) Induction of Drug Metabolism: the Role of Nuclear Receptors. *Pharmacol Rev* **55**: pp 649-673.

Handschin C, Rhee J, Lin J, Tarr P T and Spiegelman B M (2003) An Autoregulatory Loop Controls Peroxisome Proliferator-Activated Receptor Gamma Coactivator 1alpha Expression in Muscle. *Proc Natl Acad Sci U S A* **100**: pp 7111-7116.

Honkakoski P, Zelko I, Sueyoshi T and Negishi M (1998) The Nuclear Orphan Receptor CAR-Retinoid X Receptor Heterodimer Activates the Phenobarbital-Responsive Enhancer Module of the CYP2B Gene. *Mol Cell Biol* **18**: pp 5652-5658.

Huang W, Zhang J, Chua S S, Qatanani M, Han Y, Granata R and Moore D D (2003) Induction of Bilirubin Clearance by the Constitutive Androstane Receptor (CAR). *Proc Natl Acad Sci U S A* **100**: pp 4156-4161.

Ijpenberg A, Tan N S, Gelman L, Kersten S, Seydoux J, Xu J, Metzger D, Canaple L, Chambon P, Wahli W and Desvergne B (2004) In Vivo Activation of PPAR Target Genes by RXR Homodimers. *EMBO J* **23**: pp 2083-2091.

Jinno H, Tanaka-Kagawa T, Hanioka N, Ishida S, Saeki M, Soyama A, Itoda M, Nishimura T, Saito Y, Ozawa S, Ando M and Sawada J (2004) Identification of Novel Alternative Splice Variants of Human

Constitutive Androstane Receptor and Characterization of Their Expression in the Liver. *Mol Pharmacol* **65**: pp 496-502.

Kawamoto T, Sueyoshi T, Zelko I, Moore R, Washburn K and Negishi M (1999) Phenobarbital-Responsive Nuclear Translocation of the Receptor CAR in Induction of the CYP2B Gene. *Mol Cell Biol* **19**: pp 6318-6322.

Khorasanizadeh S and Rastinejad F (2001) Nuclear-Receptor Interactions on DNA-Response Elements. *Trends Biochem Sci* **26**: pp 384-390.

Kocarek TA and Mercer-Haines N A (2002) Squalestatin 1-Inducible Expression of Rat CYP2B: Evidence That an Endogenous Isoprenoid Is an Activator of the Constitutive Androstane Receptor. *Mol Pharmacol* **62**: pp 1177-1186.

Kozak M (1987) An Analysis of 5'-Noncoding Sequences From 699 Vertebrate Messenger RNAs. *Nucleic Acids Res* **15**: pp 8125-8148.

Lamba JK, Lamba V, Yasuda K, Lin Y S, Assem M, Thompson E, Strom S and Schuetz E G (2004) Expression of CAR Splice Variants in Human Tissues and Their Functional Consequences. *J Pharmacol Exp Ther* **311**: pp 811-821.

Maglich JM, Parks D J, Moore L B, Collins J L, Goodwin B, Billin A N, Stoltz C A, Kliewer S A, Lambert M H, Willson T M and Moore J T (2003) Identification of a Novel Human Constitutive Androstane Receptor (CAR) Agonist and Its Use in the Identification of CAR Target Genes. *J Biol Chem* **278**: pp 17277-17283.

Maglich JM, Stoltz C M, Goodwin B, Hawkins-Brown D, Moore J T and Kliewer S A (2002) Nuclear Pregnane x Receptor and Constitutive Androstane Receptor Regulate Overlapping but Distinct Sets of Genes Involved in Xenobiotic Detoxification. *Mol Pharmacol* **62**: pp 638-646.

- Maglich JM, Watson J, McMillen P J, Goodwin B, Willson T M and Moore J T (2004) The Nuclear Receptor CAR Is a Regulator of Thyroid Hormone Metabolism During Caloric Restriction. *J Biol Chem* **279**: pp 19832-19838.
- Min G, Kemper J K and Kemper B (2002) Glucocorticoid Receptor-Interacting Protein 1 Mediates Ligand-Independent Nuclear Translocation and Activation of Constitutive Androstane Receptor in Vivo. *J Biol Chem* **277**: pp 26356-26363.
- Moore LB, Parks D J, Jones S A, Bledsoe R K, Consler T G, Stimmel J B, Goodwin B, Liddle C, Blanchard S G, Willson T M, Collins J L and Kliewer S A (2000) Orphan Nuclear Receptors Constitutive Androstane Receptor and Pregnane X Receptor Share Xenobiotic and Steroid Ligands. *J Biol Chem* **275**: pp 15122-15127.
- Moraitis AN, Giguere V and Thompson C C (2002) Novel Mechanism of Nuclear Receptor Corepressor Interaction Dictated by Activation Function 2 Helix Determinants. *Mol Cell Biol* **22**: pp 6831-6841.
- Nomenclature Report (1999) A Unified Nomenclature System for the Nuclear Receptor Superfamily. *Cell* **97**: pp 161-163.
- Saini SP, Sonoda J, Xu L, Toma D, Uppal H, Mu Y, Ren S, Moore D D, Evans R M and Xie W (2004) A Novel Constitutive Androstane Receptor-Mediated and CYP3A-Independent Pathway of Bile Acid Detoxification. *Mol Pharmacol* **65**: pp 292-300.
- Savkur RS, Wu Y, Bramlett K S, Wang M, Yao S, Perkins D, Totten M, Searfoss G, III, Ryan T P, Su E W and Burris T P (2003) Alternative Splicing Within the Ligand Binding Domain of the Human Constitutive Androstane Receptor. *Mol Genet Metab* **80**: pp 216-226.
- Steinmetz AC, Renaud J P and Moras D (2001) Binding of Ligands and Activation of Transcription by Nuclear Receptors. *Annu Rev Biophys Biomol Struct* **30**: pp 329-359.

Stoner M, Saville B, Wormke M, Dean D, Burghardt R and Safe S (2002) Hypoxia Induces Proteasome-Dependent Degradation of Estrogen Receptor Alpha in ZR-75 Breast Cancer Cells. *Mol Endocrinol* **16**: pp 2231-2242.

Sueyoshi T, Kawamoto T, Zelko I, Honkakoski P and Negishi M (1999) The Repressed Nuclear Receptor CAR Responds to Phenobarbital in Activating the Human CYP2B6 Gene. *J Biol Chem* **274**: pp 6043-6046.

Sugatani J, Kojima H, Ueda A, Kakizaki S, Yoshinari K, Gong Q H, Owens I S, Negishi M and Sueyoshi T (2001) The Phenobarbital Response Enhancer Module in the Human Bilirubin UDP-Glucuronosyltransferase UGT1A1 Gene and Regulation by the Nuclear Receptor CAR. *Hepatology* **33**: pp 1232-1238.

Treuter E, Albrektsen T, Johansson L, Leers J and Gustafsson J A (1998) A Regulatory Role for RIP140 in Nuclear Receptor Activation. *Mol Endocrinol* **12**: pp 864-881.

Tzamelis I, Pissios P, Schuetz E G and Moore D D (2000) The Xenobiotic Compound 1,4-Bis[2-(3,5-Dichloropyridyloxy)]Benzene Is an Agonist Ligand for the Nuclear Receptor CAR. *Mol Cell Biol* **20**: pp 2951-2958.

Ueda A, Hamadeh H K, Webb H K, Yamamoto Y, Sueyoshi T, Afshari C A, Lehmann J M and Negishi M (2002) Diverse Roles of the Nuclear Orphan Receptor CAR in Regulating Hepatic Genes in Response to Phenobarbital. *Mol Pharmacol* **61**: pp 1-6.

Urnov F D and Wolffe A P (2001) A Necessary Good: Nuclear Hormone Receptors and Their Chromatin Templates. *Mol Endocrinol* **15**: pp 1-16.

Vivat-Hannah V, Bourguet W, Gottardis M and Gronemeyer H (2003) Separation of Retinoid X Receptor Homo- and Heterodimerization Functions. *Mol Cell Biol* **23**: pp 7678-7688.

Wang H, Faucette S, Sueyoshi T, Moore R, Ferguson S, Negishi M and LeCluyse E L (2003a) A Novel Distal Enhancer Module Regulated by Pregnane X Receptor/Constitutive Androstane Receptor Is Essential for the Maximal Induction of CYP2B6 Gene Expression. *J Biol Chem* **278**: pp 14146-14152.

Wang H and LeCluyse E L (2003) Role of Orphan Nuclear Receptors in the Regulation of Drug-Metabolising Enzymes. *Clin Pharmacokinet* **42**: pp 1331-1357.

Wang X, Le R, I, Nicodeme E, Li R, Wagner R, Petros C, Churchill G A, Harris S, Darvasi A, Kirilovsky J, Roubertoux P L and Paigen B (2003b) Using Advanced Intercross Lines for High-Resolution Mapping of HDL Cholesterol Quantitative Trait Loci. *Genome Res* **13**: pp 1654-1664.

Wei P, Zhang J, Egan-Hafley M, Liang S and Moore D D (2000) The Nuclear Receptor CAR Mediates Specific Xenobiotic Induction of Drug Metabolism. *Nature* **407**: pp 920-923.

Xie W, Yeuh M F, Radominska-Pandya A, Saini S P, Negishi Y, Bottroff B S, Cabrera G Y, Tukey R H and Evans R M (2003) Control of Steroid, Heme, and Carcinogen Metabolism by Nuclear Pregnane X Receptor and Constitutive Androstane Receptor. *Proc Natl Acad Sci U S A* **100**: pp 4150-4155.

Zelko I and Negishi M (2000) Phenobarbital-Elicited Activation of Nuclear Receptor CAR in Induction of Cytochrome P450 Genes. *Biochem Biophys Res Commun* **277**: pp 1-6.

Zhang J, Huang W, Chua S S, Wei P and Moore D D (2002) Modulation of Acetaminophen-Induced Hepatotoxicity by the Xenobiotic Receptor CAR. *Science* **298**: pp 422-424.

FOOTNOTES

Supported by a USPHS Grant from the General Medical Sciences, GM066411 (CJO) and an institutional training grant from the National Institute of Environmental Health Sciences, ES077032 (SSA).

LEGENDS FOR FIGURES

Figure 1. CAR3 transactivation of a DR-4X3 reporter is ligand dependent and facilitated by the over expression of RXR. In panels A and B, COS-1 cells were transfected with indicated expression vectors (A, pcDNA3.1 (empty vector), B, pcDNA3.1/RXR) in combination with TK-luciferase reporters containing 3 copies of a direct repeats spaced by 1 to 5 base pairs. A diagram of the vector scheme and details of the respective direct repeat elements used for the experiments conducted in panel A (- RXR) and panel B (+ RXR) are shown in the upper panel. Cells were transfected for 18 h as described in “Experimental Procedures.” On day 2 transfected cells were treated with either DMSO or 5 μ M CITCO (Panels A and B) or increasing amounts of CITCO as indicated (Panel C) for 24 h after which luciferase activity was assayed. CMV2 is an empty expression vector. Data are presented as normalized and adjusted luciferase values in which the activity of the DMSO treated CMV2/3.1 (A), DMSO treated CMV2/RXR (B), or 500 pM CITCO treated CMV2/3.1 (C) data point is set to 1. Each data point represents the mean (+/- the standard error) of 4 separate transfections.

Figure 2. Nuclear extracts from CAR3 transfected cells do not bind a DR-4 DNA probe, nor does CAR3 interact with RXR in mammalian 2-hybrid assays. A, Western blot of 40 μ g of crude nuclear extract from 24 h transfected COS-1 cells. Nuclear extracts were generated as described in the “Experimental Procedures.” Blots were probed with HRP-conjugated M2 FLAG antibody. B, 6 μ g of nuclear extract from A was used in an EMSA with a DNA probe representing 1 copy of the DR-4 element engineered into the DR-4X3 reporter. Details of the experiments are found in “Experimental Procedures.” Protein/probe mixtures were incubated with either DMSO or 5 μ M CITCO. C, Mammalian 2-hybrid assays were performed as illustrated in the figure and as described in “Experimental Procedures.” Data are presented as normalized and adjusted values where the luciferase activity of the GAL4/VP16 (empty vector/empty vector) experiment is set to 1. Each data point is represents the mean +/- the standard error of 4 separate transfections. * indicates probe retained in well.

Figure 3. Transactivation of the DR4X3 reporter by CAR3 is dependent on its DNA binding domain and AF-2 motif. The DR4X3 reporter was transfected in the presence of RXR and different forms of CAR3 with deletions illustrated and indicated in figure. Details of the transfection procedure are described in the “Experimental Procedures”. DMSO and CITCO treatments were performed 18 h post-transfection and cells were harvested and assayed 24 h after chemical treatment. Data are presented as normalized and adjusted values in which the activity of the DMSO treated 3.1 (empty vector) experiment is set to 1. Each data point represents the mean +/- the standard error of 4 separate transfections

Figure 4. RXR does not stimulate CAR3 activation by enhancing receptor nuclear accumulation. A, Nuclear extracts were generated and western blots were performed as described in “Experimental Procedures.” N= nuclear fraction, C= cytosolic. Molecular weight markers (kDa) are shown to the left of the autoradiograph. Treatment with CITCO or cotransfection with RXR had little to no effect on the nuclear/cytosolic distribution of 3XFLAG-CAR3. B, Transfections and treatments were performed as described in “Experimental Procedures” and as illustrated in the figure. Data are presented as normalized and adjusted values based on the activity of the DMSO treated VP16/3.1 experiment as set to 1. C, COS-1 cells were transfected with a CAR3-VP16 fusion construct, or a VP16 control vector, and co-transfected with CMV2/RXR. COS-1 nuclei were visualized by DAPI fluorescence. CAR3 expression and nuclear localization was visualized using a rabbit polyclonal anti-hCAR derived primary antibody (30ug/ml) and a goat-anti-rabbit-IgG-FITC secondary antibody (1:200; CALTAG Corp.). Magnification = 400X

Figure 5. Enhancement of CAR3 activity by RXR is independent of RXR’s DNA binding domain, but dependent on its AF-2 motif. The DR4X3 reporter was cotransfected into COS-1 cells in combination with CAR3 and different forms of RXR as illustrated and indicated in figure. The arrows in the figure refer to the relative positions of the Y397A RXR point mutation in the ligand binding domain region of RXR, and the deleted RXR functional region tested, respectively. Details of the transfection procedure are described in the “Experimental Procedures.” Data are presented as normalized and adjusted

values where the activity of the DMSO treated CAR3/3.1 data point was set to 1. Each data point represents the mean +/- the standard error of 4 separate transfections.

Figure 6. RXR facilitates ligand-dependent interaction between CAR and SRC-1 in mammalian 2-hybrid analysis. COS-1 cells were transfected overnight as described in “Experimental Procedures” and as illustrated in the figure. On day 2 (18 h post-transfection) cells were treated with increasing amounts of CITCO. 24 h post-treatment the cells were harvested and assayed for firefly and *Renilla* luciferase. Data are presented as normalized and adjusted values where the activity of the 500 pM CITCO treated GAL4/3.1 (empty/empty) data point was set to 1. Each data point represents the mean +/- the standard error of 4 separate transfections.

Figure 7. Clotrimazole is a ligand activator of CAR3. Transfections were performed in COS-1 cells as described in “Experimental Procedures” and as illustrated in the figure. Chemical treatments were performed 18 h post-transfection and cells were harvested and assayed 24 h after chemical treatment. 3.1 = empty expression vector. Each data point represents the mean +/- the standard error of 4 separate transfections. A, Clotrimazole treatment produces a dose-dependent and CAR3-dependent increase in DR-4X3 reporter activity. The 1 nM clotrimazole/CMV2/3.1 data point was set to 1 and all data points are adjusted accordingly. B, A mammalian 2-hybrid assay demonstrates a clotrimazole-dependent interaction between CAR3 and the SRC-1 RID that is enhanced by the cotransfection of RXR. The 1 nM clotrimazole/GAL4/3.1 data point was set to 1 and all other data points were adjusted accordingly. C, Both CITCO and clotrimazole enhance the transactivation by GAL4-CAR3-ligand binding domain. The DMSO/GAL4/3.1 data point was set to 1 and all other data points were adjusted accordingly.

Figure 8. Clotrimazole and CITCO produce CAR3-dependent activation of the DR-4X3 reporter in HEK293 cells. Transfections were performed as described in Fig. 1A and 1B with plasmids indicated in the figure. On day 1 HEK293 cells were transfected. 18 h post-transfection cells were treated with

indicated chemicals (CLOT=clotrimazole). 24 h after chemical treatment cells were harvested and luciferase activity was measured as described in the “Experimental Procedures.” CMV2 and 3.1 represent empty expression vectors. Data are presented as normalized and adjusted values where the activity of the DMSO treated CMV2/RXR data point was set to 1. Each data point represents the mean +/- the standard error of 4 separate transfections.

Figure 9. CAR3 activation of *CYP2B6* and *CYP3A4* reporters is RXR and ligand-dependent. A and B, COS-1 cells were transfected with reporter and expression plasmids as indicated in the figure and as described in “Experimental Procedures.” 18 h post-transfection cells were treated with indicated chemicals (Clot=clotrimazole). 24 h after chemical treatment cells were harvested and luciferase activity was measured as described in the “Experimental Procedures.” CMV2 and 3.1 represent empty expression vectors. Data are presented as normalized and adjusted values where the activity of the DMSO treated CMV2/3.1 experiment was set to 1. Each data point represents the mean +/- the standard error of 4 separate transfections. CAR1 transactivation of the *CYP2B6* (A) and *CYP3A4* (B) reporters was enhanced by RXR.

TABLES

TABLE I. pTracerTM-CMV2 (Invitrogen, Carlsbad, CA) Clones. The parent plasmid contains a cytomegalovirus (CMV) promoter that yields robust expression of cloned sequences when transfected into mammalian cells. This plasmid is referred to in the text as “CMV2”.

Name	• Accession • Source	PCR Primers	Amino Acids	Restriction sites
CAR1	• NM_005122 • human liver cDNA	FP:GATCGAATTCGTCATGGCCA GTAGGGAAGATGAG RP:GATCGATATCTCAGCTGCAG ATCTCCTGGAGCCAG	1-348	EcoR1/ EcoRV
CAR3	• NA • human liver cDNA	FP:GATCGAATTCGTCATGGCCA GTAGGGAAGATGAG RP:GATCGATATCTCAGCTGCAG ATCTCCTGGAGCCAG	1-353	EcoR1/ EcoRV

TABLE II. pcDNA3.1(+) (Invitrogen, Carlsbad, CA) **Clones.** The parent plasmid contains a cytomegalovirus (CMV) promoter that yields robust expression of cloned sequences when transfected into mammalian cells. This plasmid is referred to in the text as “3.1”

Name	• Accession • Source	PCR/mutagenesis (mt) Primers	Amino Acids	Restriction sites
HA-CAR3	• NA • CMV2 clone	FP: <u>GGAATTCGCCACCATGGC</u> ATACCCATACGATGTTCCAGA TTACGCTATGGCCAGTAGGGA AGATGAGC RP: BGH	N-terminal HA-Tag-1-353	EcoR1/ Xba1
CAR3-Ligand Binding Domain (LBD)	• NA • CMV2 clone	FP: GATCGAATTCGCCACCAT GGTACTGTCTGGCAGAAGCCC RP: BGH	80-352	EcoR1/ Xba1
CAR3-ΔAF2	• NA • CMV2 clone	FP:GATCGAATTCGTCATGGCC AGTAGGGAAGATGAG RP: <u>GTCTAGACTACATCA</u> TGGCAGACAGGCCCTG	1-345	EcoR1/ Xba1
RXRα	• NM_002957 • CMV2 clone described previously (Auerbach <i>et al.</i> , 2003)	FP:GATCGAATTCGCCGCCAT GGACACCAAACATTTCTG RP:GATCTCTAGACTAAGTCAT TT GGTGCGGCGC	1-462	EcoR1/ Xba1
RXRα-ΔAF1	• NA • CMV2 clone described previously (Auerbach <i>et al.</i> , 2003)	FP: <u>GGAATTCGCCACCATGGC</u> CCACCCCTCAGGAAACATG RP:GATCTCTAGACTAAGTCAT TT GGTGCGGCGC	123-462	EcoR1/ Xba1
RXRα-LBD	• NA • CMV2 clone described previously (Auerbach <i>et al.</i> , 2003)	FP: <u>GGAATTCGCCGCCATGGG</u> CATGAAGCGGGAAG RP:GATCTCTAGACTAAGTCAT TT GGTGCGGCGC	198-462	EcoR1/ Xba1
RXRα-ΔAF2	• NA • CMV2 clone described previously (Auerbach <i>et al.</i> , 2003)	FP:GATCGAATTCGCCGCCAT GGA CACCAAACATTTCTG RP:GATCTCTAGATTAGGTGTC AA TGGGTGTGTCCC	1-449	EcoR1/ Xba1
RXRα	• NA	FP:GATCGAATTCGCCGCCAT	1-462	EcoR1/

-Y397A	<ul style="list-style-type: none">• CMV2 clone described previously (Auerbach <i>et al.</i>, 2003)• based on mutagenized mouse clone (Vivat-Hannah <i>et al.</i>, 2003)	GGACACCAAACATTTCTG RP:GATCTCTAGACTAAGTCAT TTGGTGCGGCGC mtFP:GGAGAAGGTTCGCTGCGT CCTTGGAGGCCTACTGCAAG mtRP:CTTGCAGTAGGCCTCCAA GGACGCAGCGACCTTCTCC		XbaI
--------	--	---	--	------

TABLE III. p3XFLAG-CMVTM10 (Sigma, St Louis, MO) Expression Vectors. The plasmid was designed with a fusion of 3 copies of a flu antigen (FLAG) epitope tag to the N-terminus of a cloned sequence. Expression of the epitope tagged protein is by way of a CMV promoter. The 3XFLAG-BAP expression vector was supplied by Sigma.

Name	• Accession • Source	Primers for PCR-based cloning	Amino Acids	Restriction sites
CAR1	•NM_005122 • CMV2 clone	FP:GATCGAATTCTATGGCCAG TAGGGAAGATGAGC RP: BGH	1-348	EcoR1/ Xba1
CAR3	• NA • CMV2 clone	FP:GATCGAATTCTATGGCCAG TAGGGAAGATGAGC RP: BGH	1-353	EcoR1/ Xba1

TABLE IV. pM and pVP16 (BD Biosciences, Palo Alto, CA) Clones. In frame cloning of sequences into pM and VP16 generate fusion proteins of the GAL4-DNA binding domain and the viral protein 16 (VP16) activation domain, respectively. These plasmids were used in combinations to access interaction of proteins in mammalian cells. The multiple cloning sites of the plasmids are identical, therefore cloned sequences are interchangeable. The luciferase reporter employed in the mammalian 2-hybrid assays was pFR-Luc (Stratagene, La Jolla, CA)

Name	• Accession • Source	Primers	Amino Acids	Restriction sites
CAR1	• NA • CMV2 clone	FP:GATCGAATTCGTCATGGC CAGTAGGGAAGATGAG RP: BGH	1-348	EcoR1/ Xba1
CAR1-LBD	• NA • CMV2 clone	FP: GATCGAATTCGCCACCAT GGTACTGTCCGCGAGAAGCCC RP: BGH	80-348	EcoR1/ Xba1
CAR3-	• NA • CMV2 clone	FP:GATCGAATTCGTCATGGC CAGTAGGGAAGATGAG RP: BGH	1-352	EcoR1/ Xba1
CAR1-LBD	• NA • CMV2 clone	FP: GATCGAATTCGCCACCAT GGTACTGTCCGCGAGAAGCCC RP: BGH	80-352	EcoR1/ Xba1
SRC-1 Receptor Interaction Domain (RID)	• NM_003743 • Human liver cDNA	FP: GATCGAATTCCTAGCAG ATTAAATATACAACCAG RP: GATCTCTAGATCACATCT GTTCTTTCTTTTCCACTT	570-780	EcoR1/ Xba1
RXR α	• NM_002957 • CMV2 clone described previously (Auerbach <i>et al.</i> , 2003)	FP:GATCGAATTCGCCGCCAT GGACACCAAACATTTCTG RP:GATCTCTAGACTAAGTCA TTT GGTGCGGCGC	1-462	EcoR1/ Xba1
RXR α -LBD	• NA • CMV2 clone described previously (Auerbach <i>et al.</i> , 2003)	FP: GGAATTCGCCGCCATGGG CATGAAGCGGGAAG RP:GATCTCTAGACTAAGTCA TTT GGTGCGGCGC	198-462	EcoR1/ Xba1

MOL 13417 Figure 1A

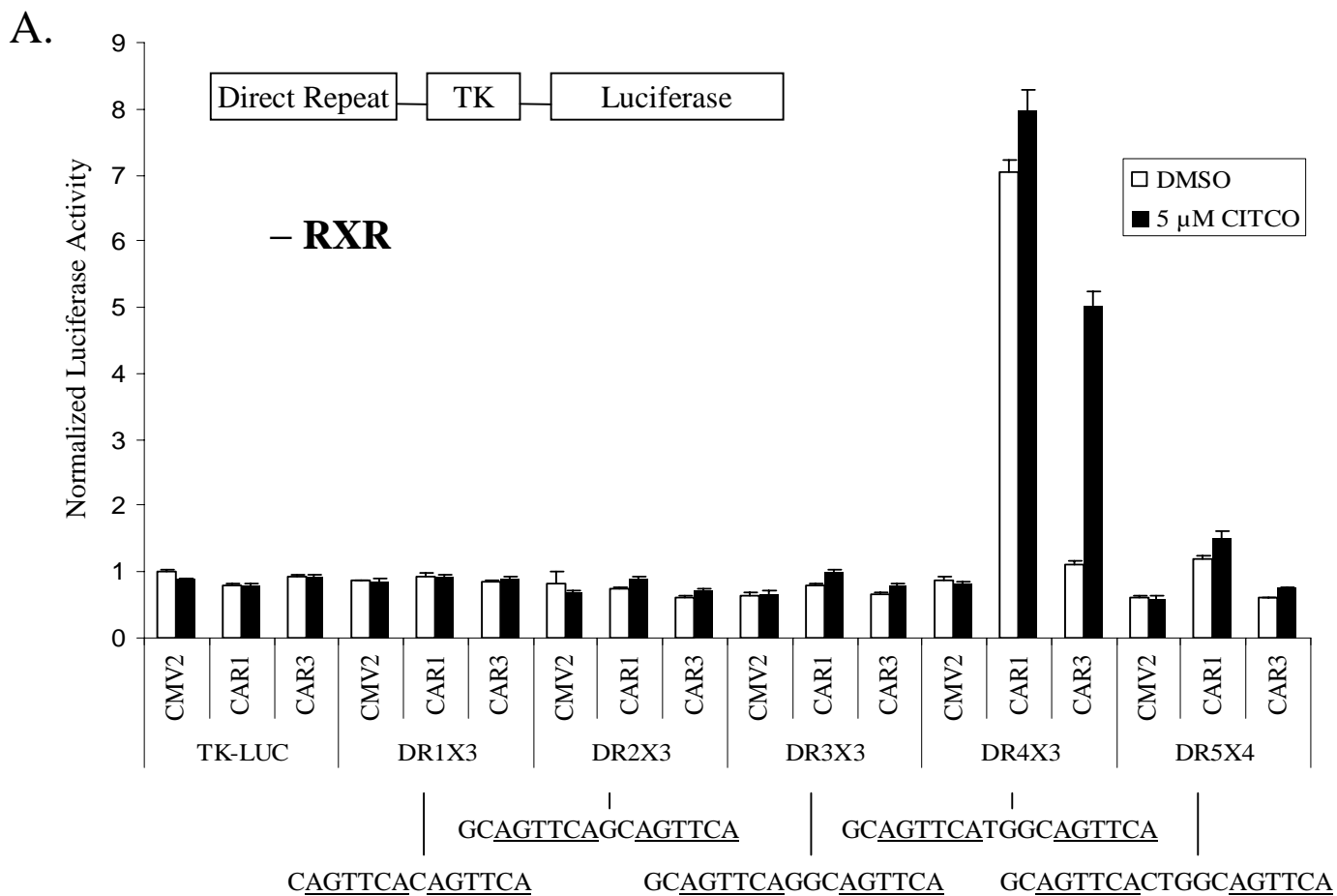

MOL 13417 Figure 1B

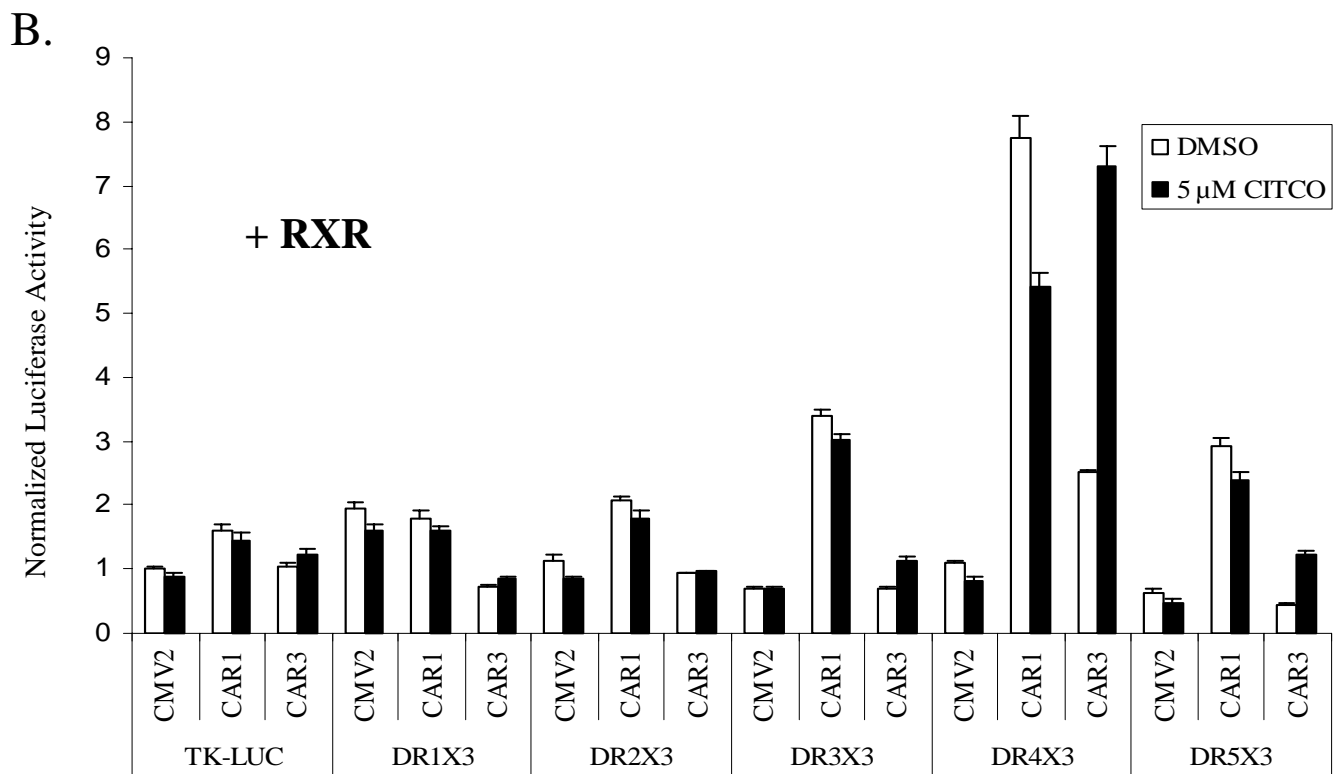

MOL 13417 Figure 1C

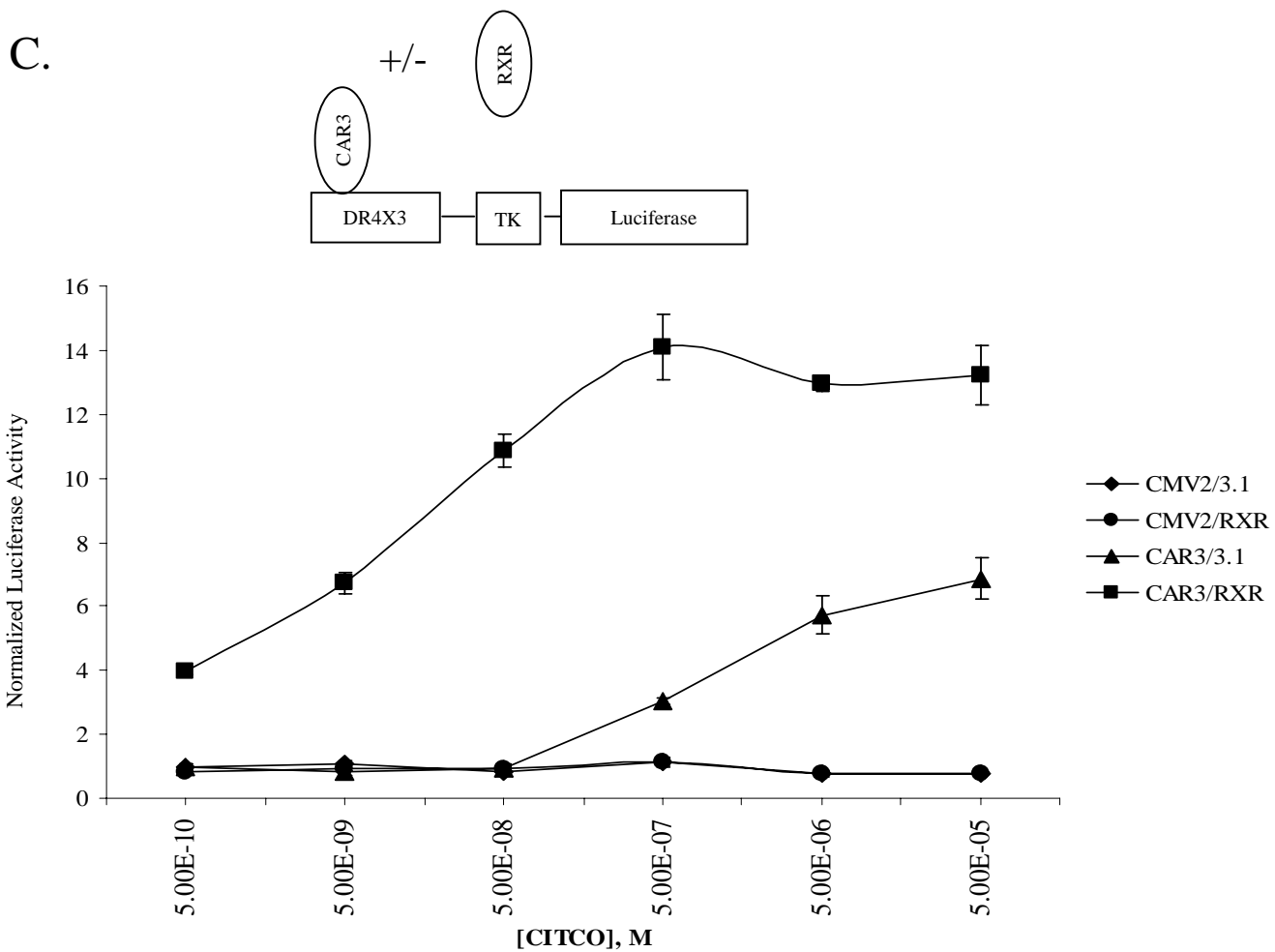

MOL 13417 Figure 2A

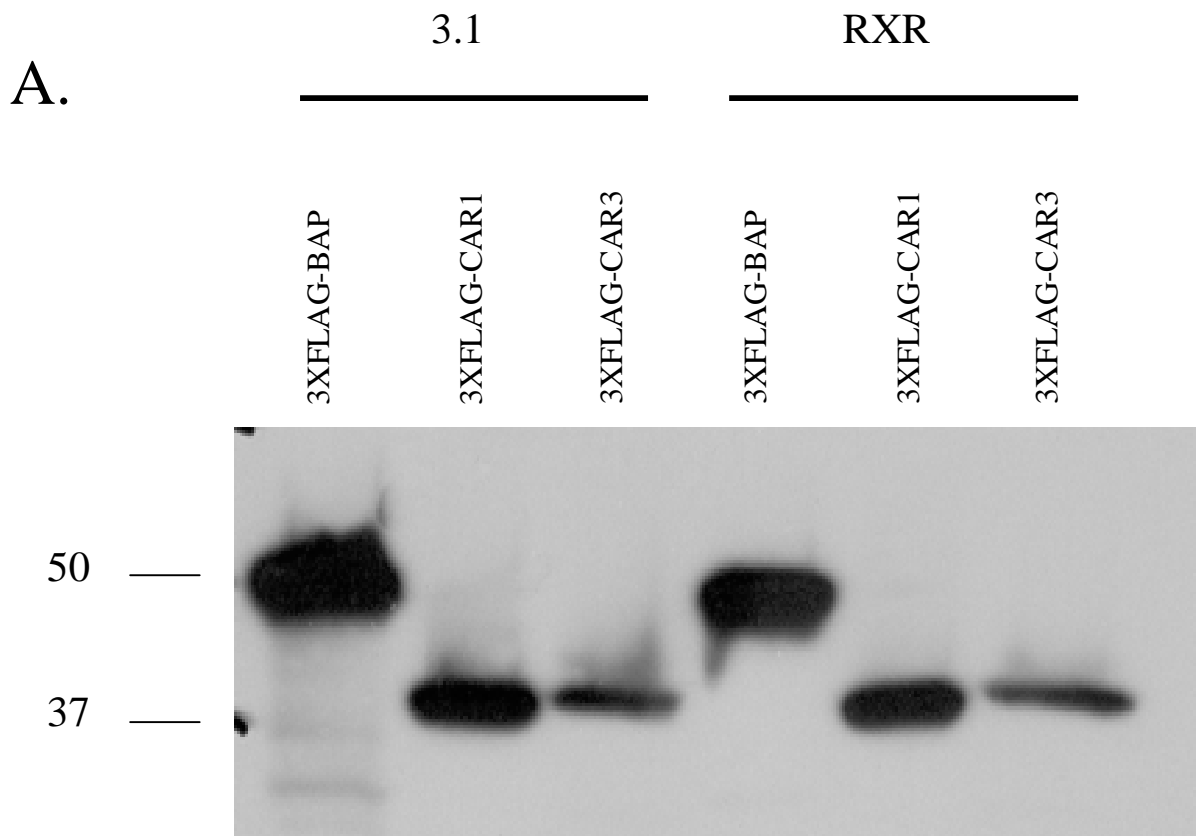

MOL 13417 Figure 2B

B.

Annealed probe: 5'-GAGCAGTTCATGGCAGTTCATG-3'
 3'-CGTCAAGTACCGTCAAGTACAG-5'

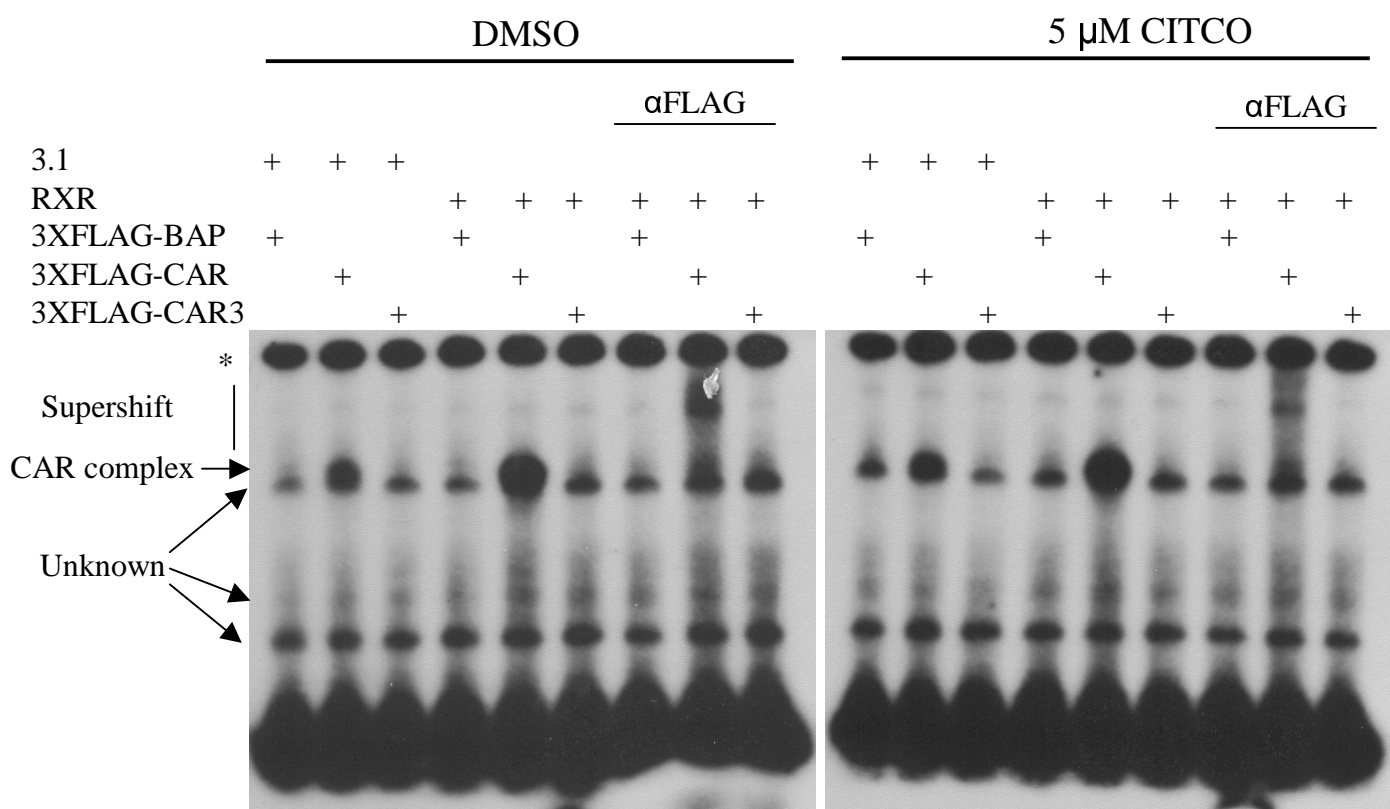

MOL 13417 Figure 2C

C.

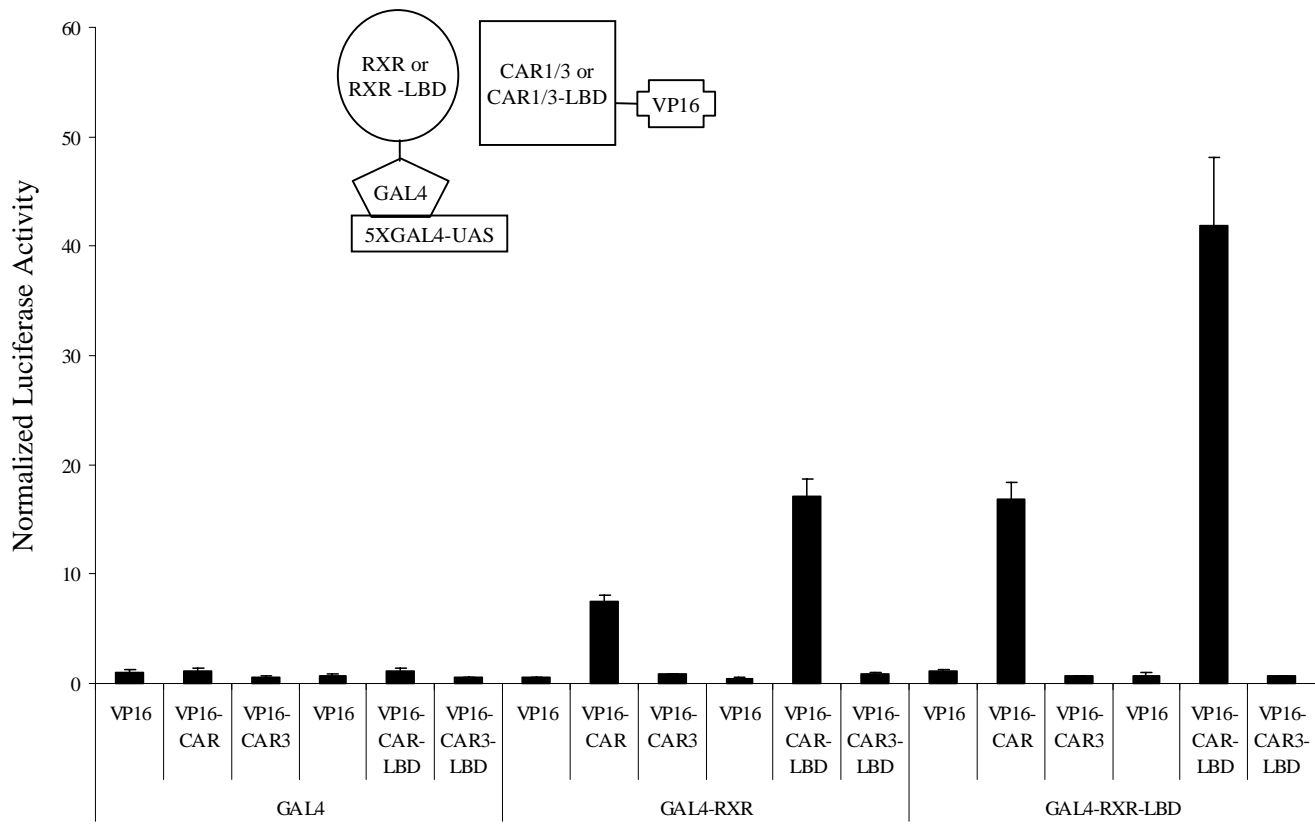

MOL 13417 Figure 3

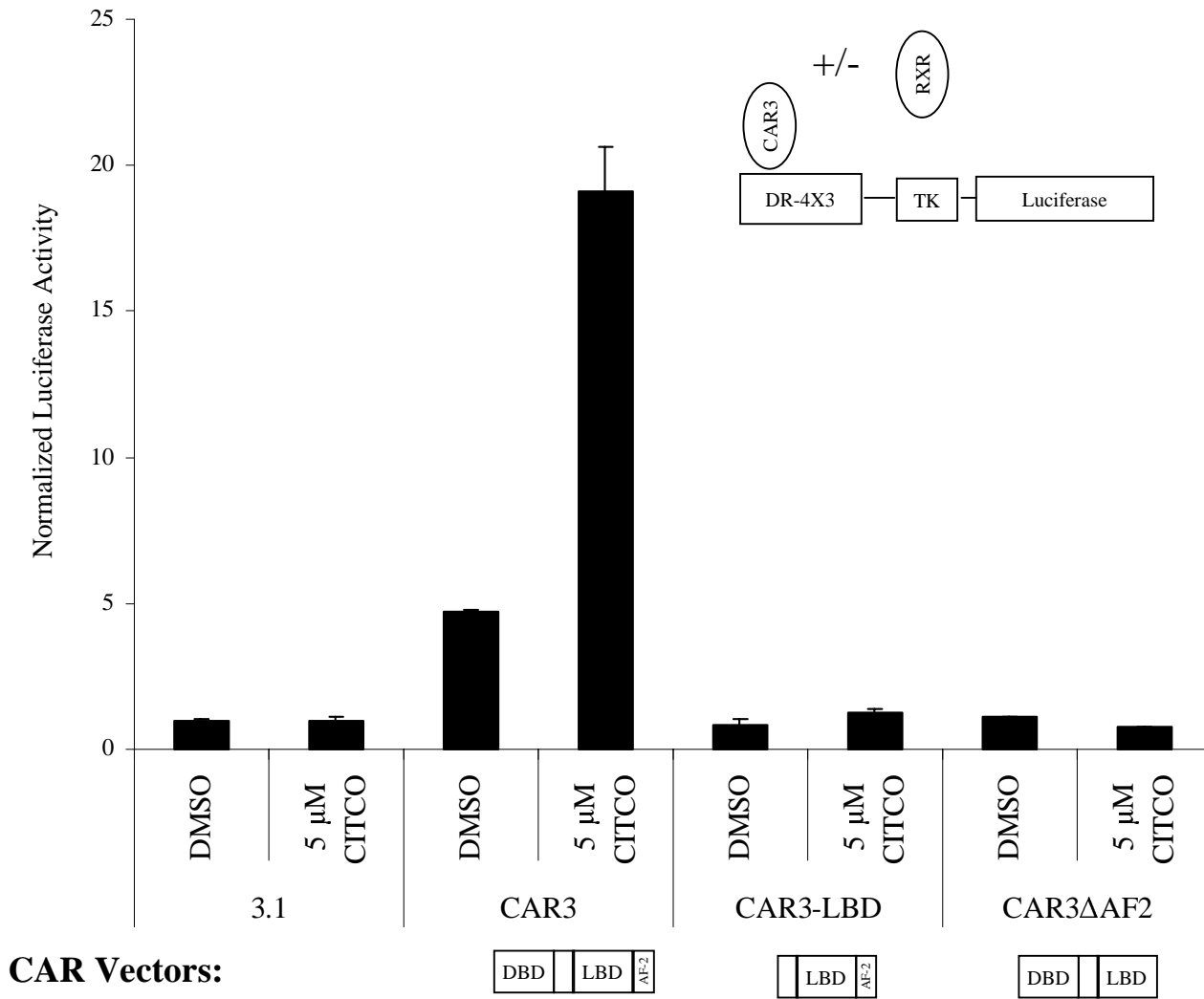

MOL 13417 Figure 4A

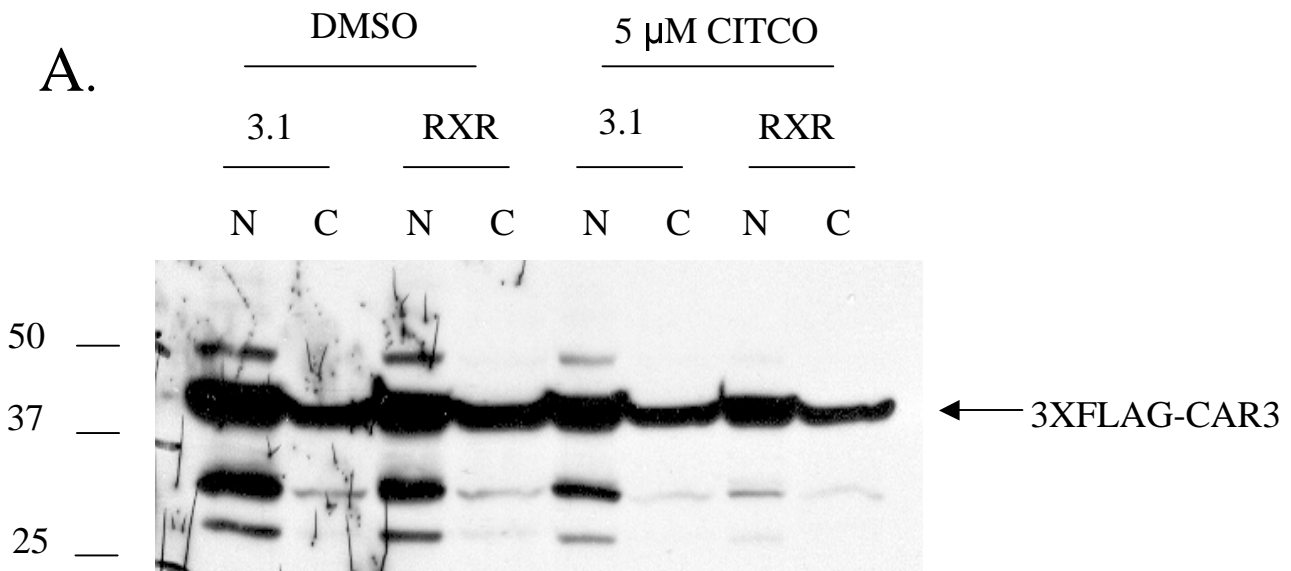

MOL 13417 Figure 4B

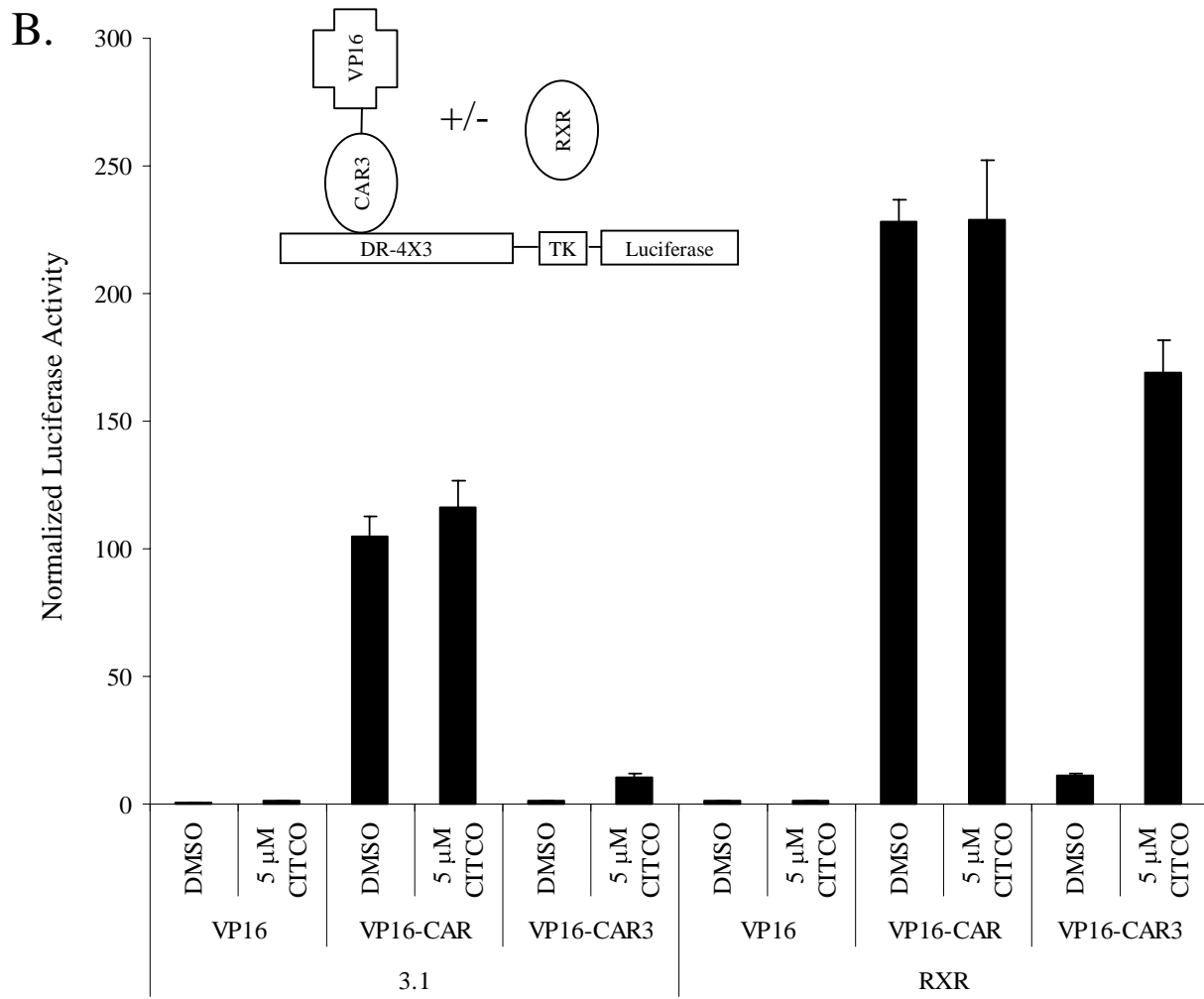

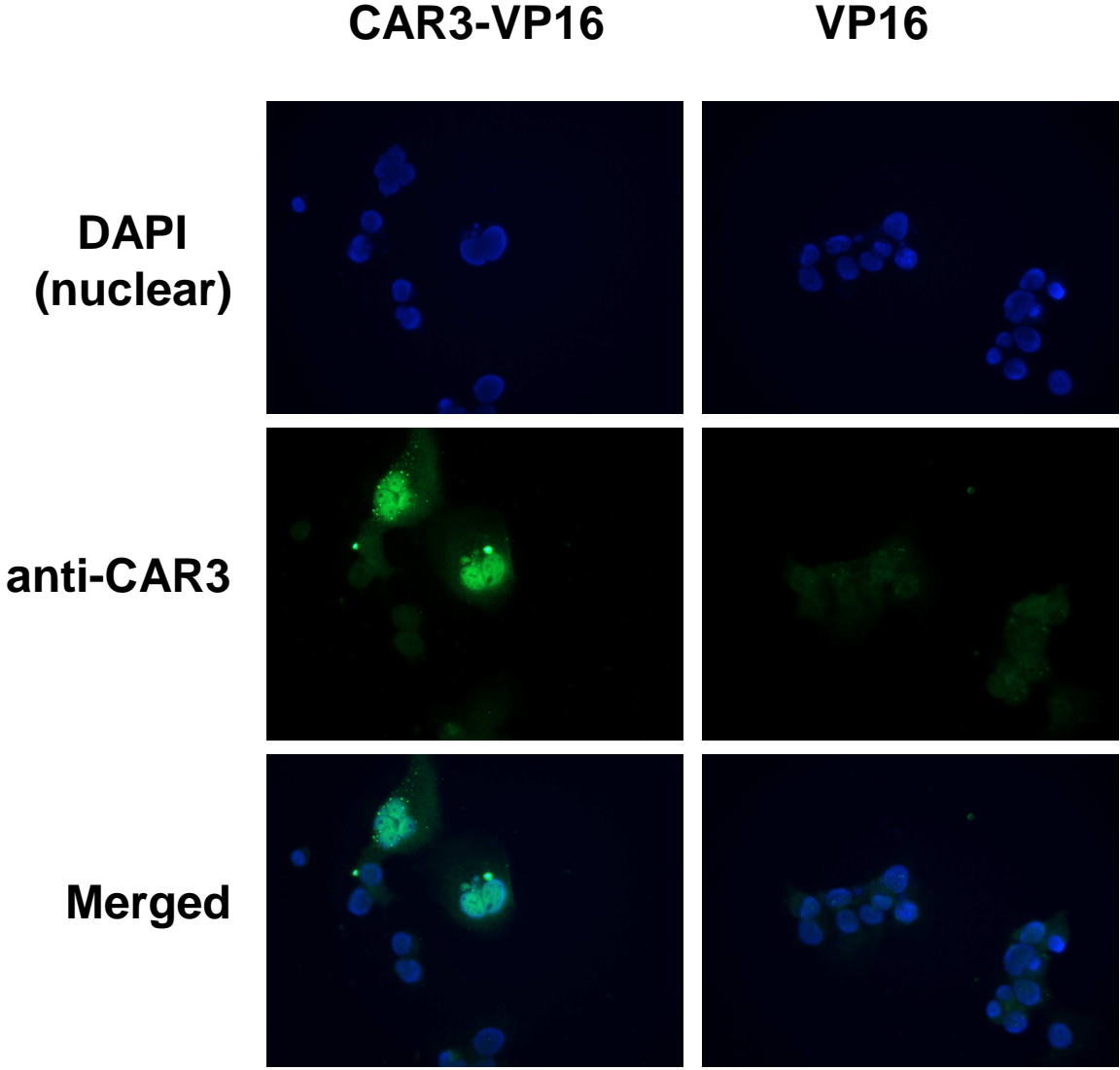

MOL 13417 Figure 5

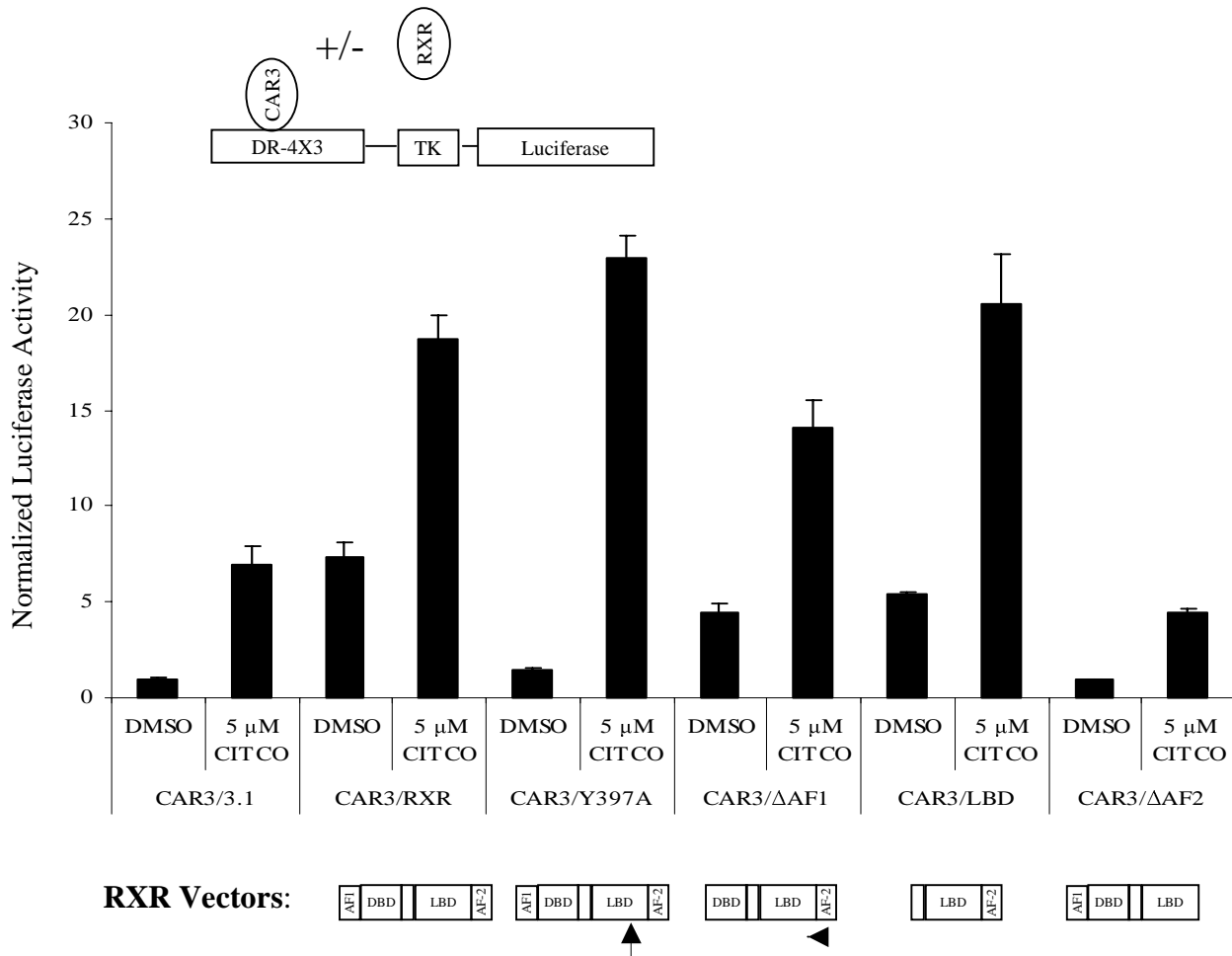

MOL 13417 Figure 6

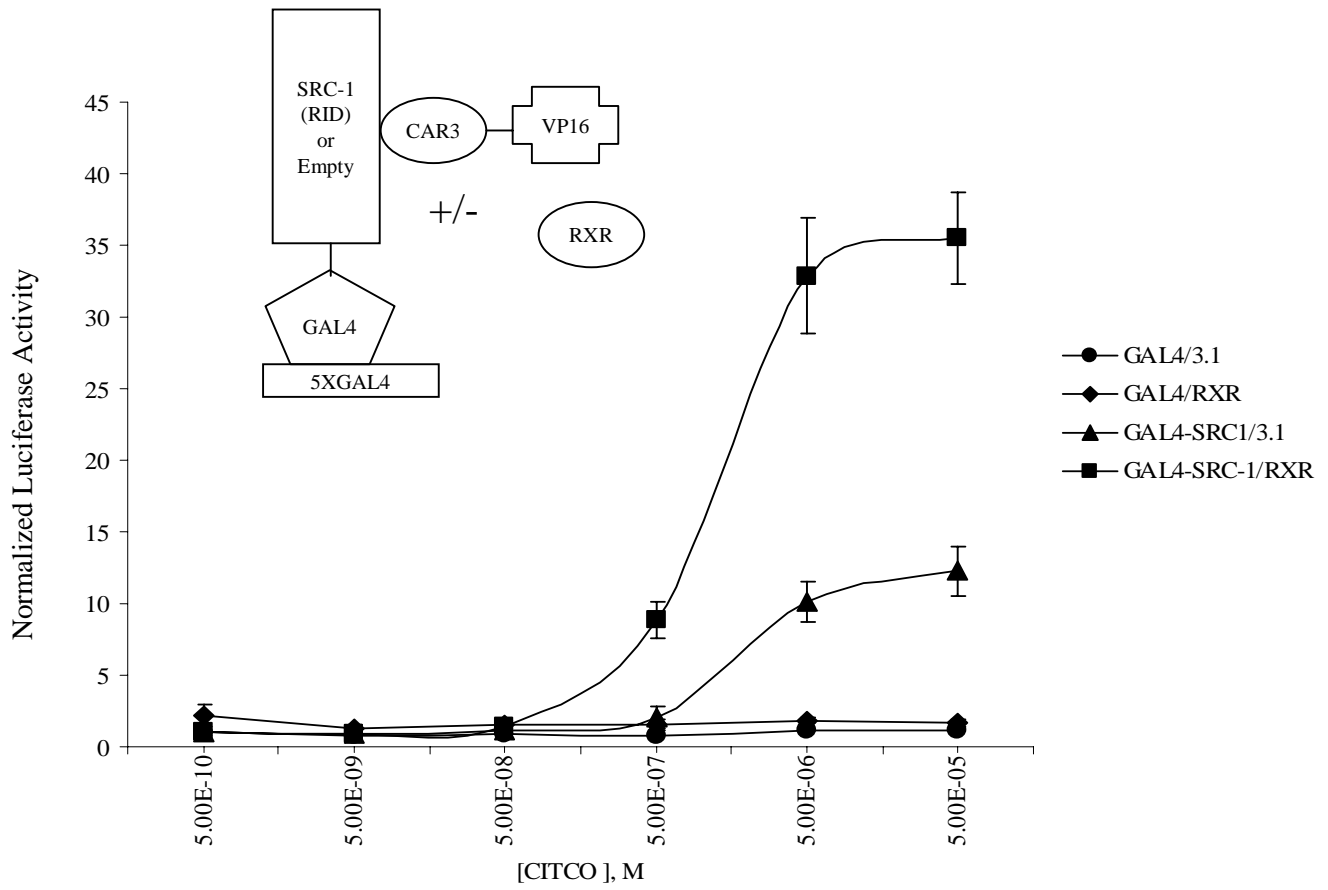

MOL 13417 Figure 7A

A.

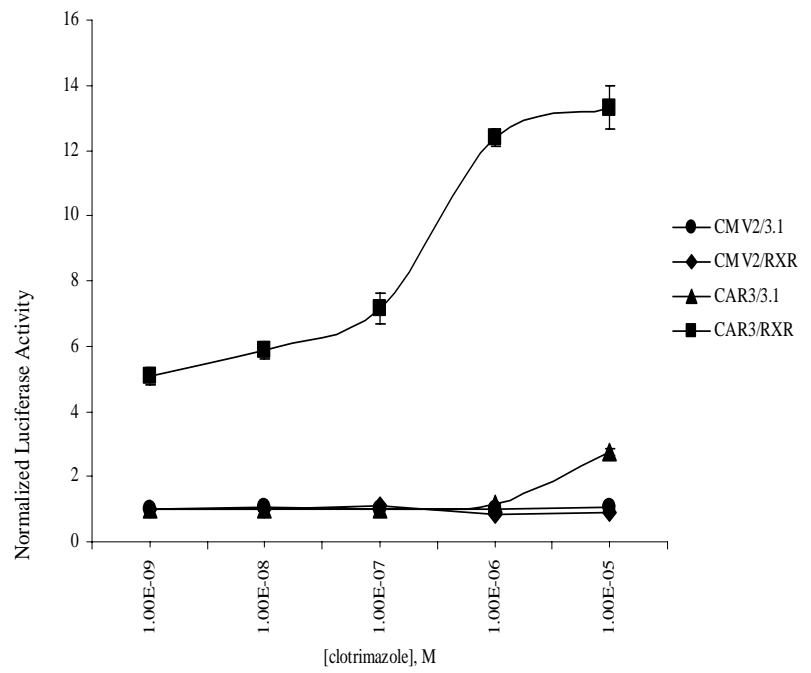
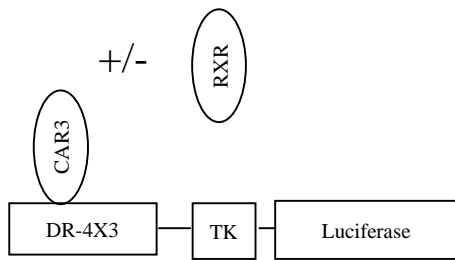

MOL 13417 Figure 7B

B.

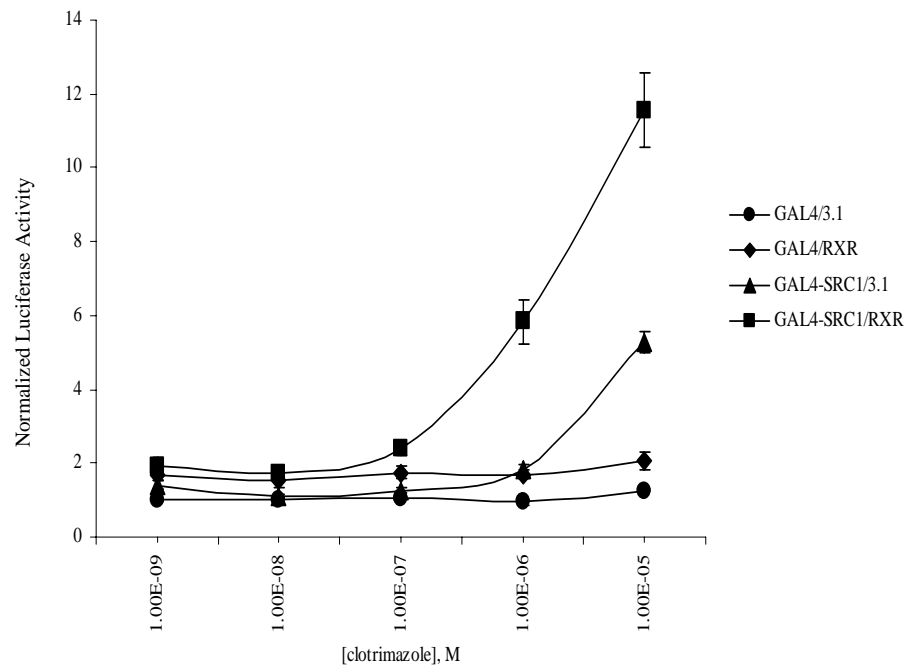
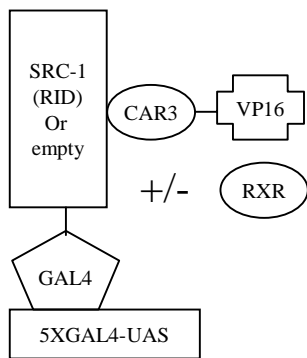

MOL 13417 Figure 7C

C.

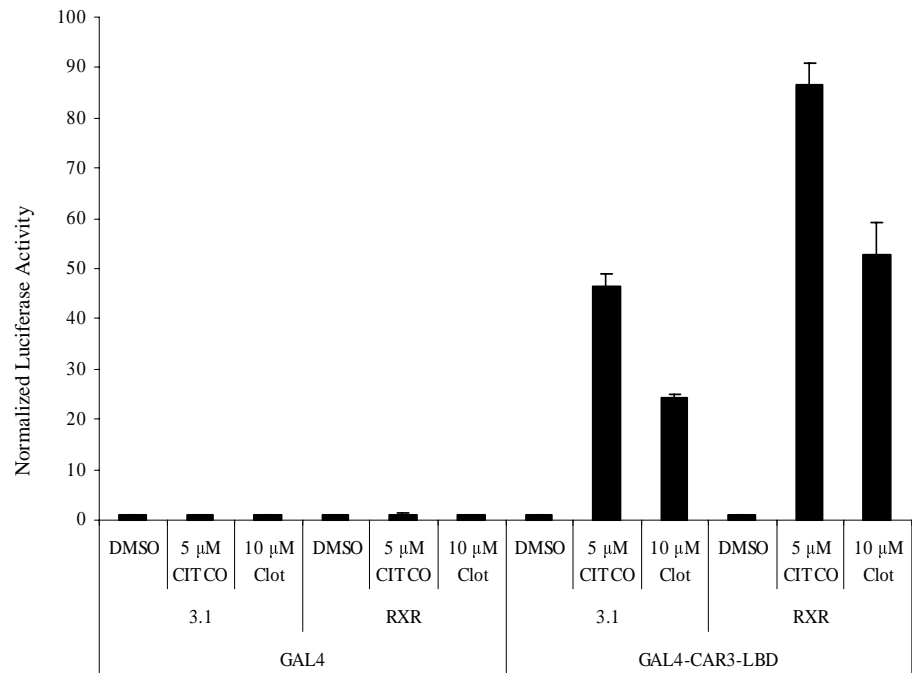
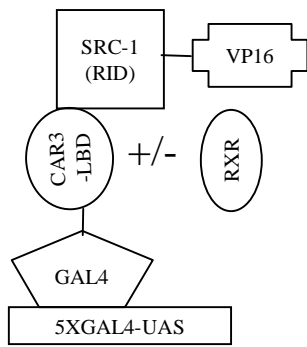

MOL 13417 Figure 8

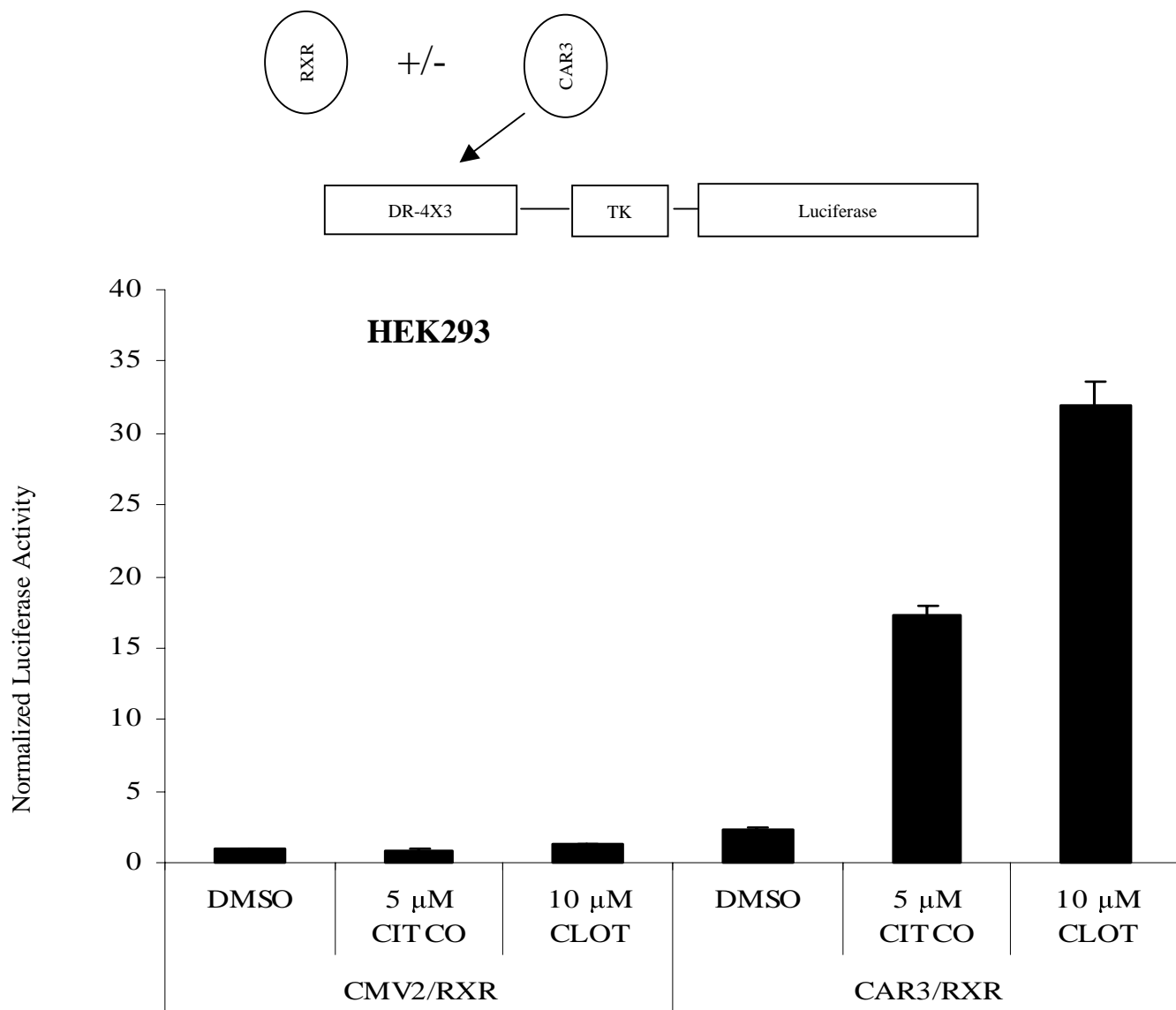

MOL 13417 Figure 9A

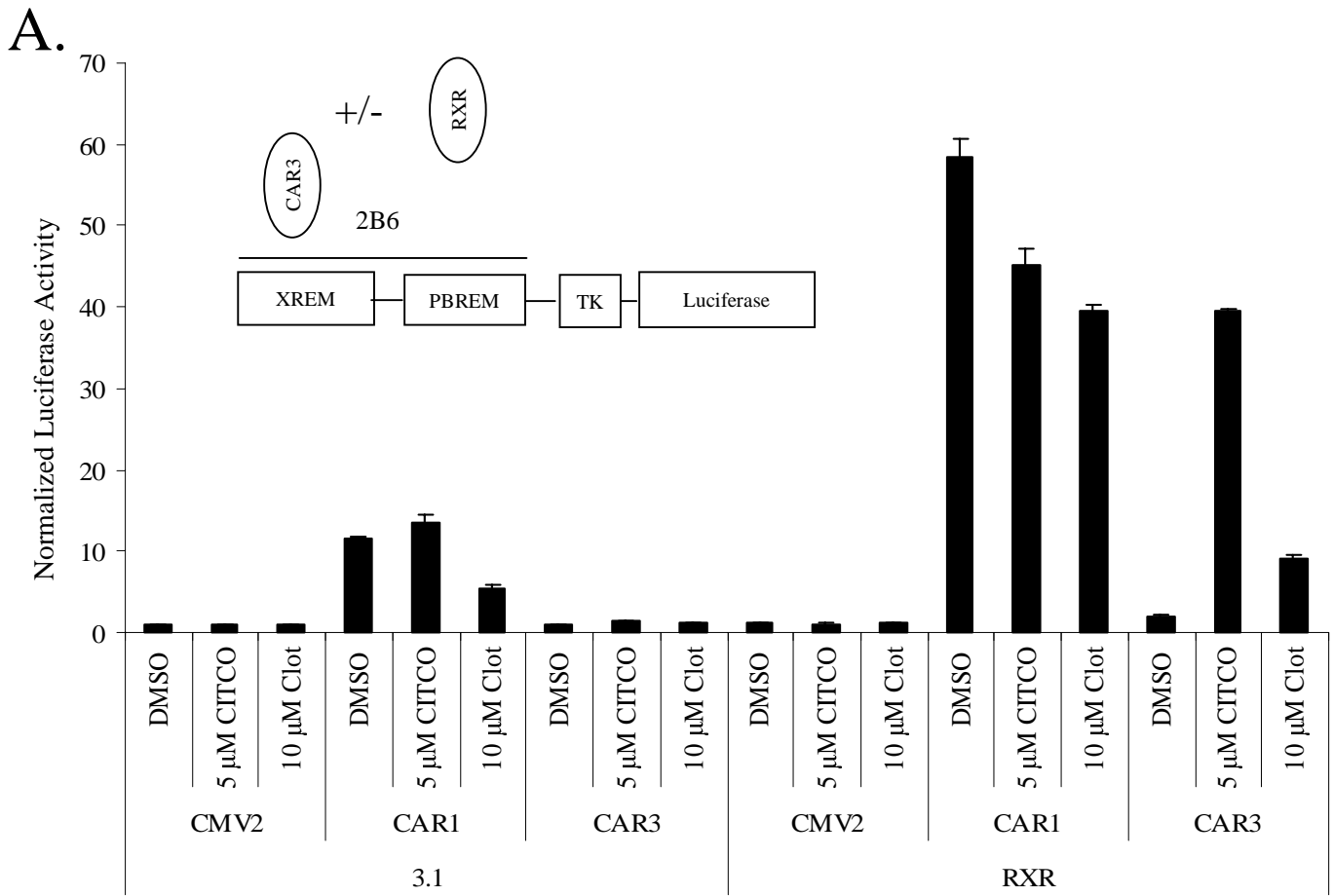

MOL 13417 Figure 9B

B.

