

MOL #47068

Title Page

**A Hypomorphic Allele of *Aryl-hydrocarbon Receptor-associated-protein-9*
Produces a Phenocopy of the *Ahr* Null**

Bernice C. Lin, Linh P. Nguyen, Jacqueline A. Walisser and Christopher A. Bradfield†

From The McArdle Laboratory for Cancer Research

MOL #47068

RUNNING TITLE PAGE

Hypomorphic *Ara9* mice are a phenocopy of *Ahr*^{-/-} mice

Corresponding Author: Christopher Bradfield, Ph.D., 1400 University Ave, Madison, WI, 53706. Phone:
608-262-2024; Fax: 608-262-2824; E-mail: bradfield@oncology.wisc.edu

Text Pages = 12

Figures = 3

References = 25

Words in Abstract = 170

Words in Introduction = 543

Words in Results = 550

Words in Discussion = 1020

Non-standard Abbreviations:

ARA9, aryl hydrocarbon receptor-associated protein 9; XAP2, hepatitis B virus X-associated protein 2;
AIP1, aryl hydrocarbon receptor-interacting protein 1; AHR, aryl hydrocarbon receptor; FKBP, FK506-
binding protein; TPR, tetratricopeptide repeat.

MOL #47068

ABSTRACT

The aryl hydrocarbon receptor associated protein-9 (ARA9) is a chaperone of the aryl hydrocarbon receptor (AHR). The AHR has been shown to play a late developmental role in the normal closure of a fetal hepato-vascular shunt known as the ductus venosus (DV). Given that *Ara9* null mice display early embryonic lethality, we generated a hypomorphic *Ara9* allele (designated *Ara9^{fxneo}*) that displays reduced ARA9 protein expression. In an effort to demonstrate the role of ARA9 protein in AHR-mediated DV closure, we used combinations of *Ara9* wildtype (*Ara9^{+/+}*), null (*Ara9^{-/-}*) and hypomorphic (*Ara9^{fxneo}*) alleles to produce mice with a graded expression of the ARA9 protein. Liver perfusion studies demonstrated that while none of the *Ara9^{+/+}* mice displayed a patent DV, the shunt was observed in 10% of the *Ara9^{+/fxneo}* mice, 55% of the *Ara9^{+/-}* mice and 83% of the *Ara9^{fxneo/fxneo}* mice. The fact that expression level of ARA9 correlates with the frequency of a phenocopy of the *Ahr* null allele supports the conclusion that the ARA9 protein is essential for AHR signaling during development.

MOL #47068

INTRODUCTION

The aryl hydrocarbon receptor (AHR) is a ligand-activated transcription factor best known for mediating the adaptive and toxic responses to polycyclic aromatic hydrocarbons and halogenated dibenzo-*p*-dioxins (Eisen et al., 1983; Poland, 1982). Once these ligands such as these bind the receptor, the complex translocates to the nucleus where the AHR dissociates and dimerizes with its transcriptional partner, the aryl hydrocarbon receptor nuclear translocator (ARNT). In the nucleus, the AHR/ARNT dimer binds to cognate “dioxin responsive elements” (DREs) in the enhancer regions of responsive genes, resulting in the transcriptional upregulation of those genes (Henry and Gasiewicz, 1993; Hord and Perdew, 1994; Reyes et al., 1992). The effects mediated by this pathway include the adaptive upregulation of certain cytochromes P450, as well as toxic endpoints that include thymic involution, hepatocellular damage, and cleft palate (Poland and Knutson, 1982).

It has been shown recently that the AHR also plays an important role in hepato-vascular development (Lahvis et al., 2005). In the developing embryo, the DV serves as a shunt that connects the umbilical cord blood with blood from the portal vein and the inferior *vena cava* (IVC) (Schermerhorn et al., 1996). The DV normally closes within a few hours or days of parturition. Although *Ahr*^{-/-} mice are viable and fertile, a consistent phenotype observed in these animals is the presence of an open, or patent, *ductus venosus* (DV) throughout life (Lahvis et al., 2005). Failure of DV closure in *Ahr*^{-/-} mouse models causes a decrease in portal blood supply to the liver, thereby limiting nutrients and decreasing overall liver size (Lahvis et al., 2005).

The cytosolic form of the receptor has been shown to be complexed with a dimer of heat shock protein 90 (Hsp90) and either the co-chaperone p23 or the aryl hydrocarbon receptor-associated protein-9 (ARA9) (Carver and Bradfield, 1997; Hollingshead et al., 2004; Shetty et al., 2003). The ARA9 protein is

MOL #47068

also known as the aryl hydrocarbon receptor interacting protein (AIP) or the X-protein associated protein-2 (XAP2) (Ma and Whitlock, 1997; Meyer and Perdew, 1999). In an effort to understand whether ARA9 plays a role in the developmental aspect of AHR signal transduction, we employed gene targeting techniques to generate a series of hypomorphic alleles at the *Ara9* locus in mice. The approach of using hypomorphic alleles at *Ara9* was employed because mice harboring an *Ara9* null allele (i.e., *Ara9*^{-/-}) display 100% embryonic lethality due to a number of embryonic heart defects (Lin et al., 2007). Given that *Ahr*^{-/-} null mice do not display similar congenital heart defects, we conclude that ARA9 plays a role in heart development that is independent of its role in AHR function (Fernandez-Salguero et al., 1996; Schmidt et al., 1996).

Our use of *Ara9* hypomorphic models was based upon two predictions. First, we hypothesized that mice hypomorphic for *Ara9* could be developed which would express enough protein to alleviate the developmental block caused by the essential role of the protein in early cardiac development. Second, if ARA9 was essential for AHR-developmental signaling, then mice with a lower level of ARA9 protein expression would also display a phenocopy of the *Ahr* null animal, i.e., a patent DV. We show here that these criteria can indeed be met and furthermore, we provide the first evidence that ARA9 is essential for AHR-mediated developmental signaling.

MATERIALS AND METHODS

Construction of the Ara9^{fxneo} targeting vector. Creation of the *Ara9^{fxneo}* targeting vector is identical to the creation of $\Delta CAra9^{fxneo}$ and is described in Figure 1 and in previous work from our lab (Lin et al., 2007). A *Bam*HI restriction enzyme analysis resulting in fragment sizes of 553 bp, 844 bp, and 11,165 bp was performed to confirm the orientation of components of the targeting vector (PL 2008),

MOL #47068

including the TPR domains, Lox P sites, and arms of homology. Embryonic stem cell culture conditions and genotyping were performed using the same methods as previously reported (Lin et al., 2007).

Visualization of the ductus venosus - Mice harboring a patent DV were identified by perfusion of the liver with a solution of Trypan Blue using methods previously described (Walisser et al., 2004a). The status of the DV was confirmed on a subset of livers *via* time-lapse angiography using a method described previously in (Walisser et al., 2004b).

Western blot analysis - Western blots were performed using the same methods described previously in (Lin et al., 2007).

Statistics – In experimental analysis of multiple comparisons, an analysis of variance was performed, and Tukey’s test was used to determine differences with a $p \leq 0.05$. Statistical analysis of genotype distribution was compared by chi square analysis (Devore and Peck, 1986).

MOL #47068

RESULTS

Generation and genotyping of Ara9^{fxneo} mice. Homologous recombination of the Ara9^{fxneo} targeting construct (Figure 1A) into ES cells was confirmed by Southern blot analysis of *BamHI* digested genomic DNA. The wild-type and Ara9^{fxneo} recombinant allele gives rise to bands at 2.7 kb and 3.9 kb, respectively (Figure 1B). Progeny resulting from a heterozygote by heterozygote cross were as follows: 12/52 (23 %) were Ara9^{+/+}, 30/52 (58 %) were Ara9^{+/fxneo}, and 10/52 (19 %) were Ara9^{fxneo/fxneo} (Figure 1C). The ratio of the genotypes obtained from chi-square analysis was not significantly different than expected with a viable allele ($p \leq 1$, $X^2 = 0.69$), and indicated adherence to the expected Mendelian ratio of 1:2:1. Gross anatomy and histological examinations suggested that wildtype, heterozygote, and homozygous Ara9^{fxneo} animals are outwardly normal (data not shown).

The Ara9^{fxneo} allele is hypomorphic. The expression of ARA9 was measured by western blot analysis of protein extracts from heart, liver, kidney, spleen, and thymus from wild-type (Ara9^{+/+}) and Ara9^{fxneo/fxneo} mice (Figure 2A). Hypomorphs displayed marked decreases in ARA9 protein expression in all tissues examined. Antibodies raised against either the FKBP or TPR domains (Lin et al., 2007) yielded similar results (data not shown). Based on the ARA9 western blot gradient, expression of the ARA9 protein from the Ara9^{fxneo} allele was estimated to be approximately 10 % of the expression of the wild-type allele (Figure 2B).

The ARA9 protein is necessary for closure of the ductus venosus. To determine whether Ara9^{fxneo} mice display a patent DV similar to that observed in *Ahr*^{-/-} mice, we evaluated this phenotype by obtaining serial angiograms of contrast dye flowing through the perfused liver and by Trypan Blue perfusion (Figure 3A & B) (Lahvis et al., 2000; Walisser et al., 2004a). In the progeny from appropriate crosses of heterozygous animals, the angiograms of wild-type littermates revealed that the contrast agent flowed

MOL #47068

through the portal vein and into the branches of the liver and then into the suprahepatic then infrahepatic IVC (Figure 3A). In contrast, livers of $Ahr^{-/-}$ and $Ara9^{fxneo/fxneo}$ mice display portocaval shunting between the portal vein and IVC, indicating the presence of a patent DV (Lahvis et al., 2000). Perfusion assays using Trypan Blue were performed on a larger number of animals and revealed that $Ara9^{fxneofxneo}$ mice display a patent DV at a frequency of 83 %. Mice that are $Ara9^{+/-}$ display a DV frequency of 56%. Mice that are $Ara9^{+/fxneo}$ display a patent DV with a frequency of approximately 10% (Figure 3B). Wild-type animals ($Ara9^{+/+}$) do not display a patent DV. No association was noted between the sex of the animal and persistence of the DV (data not shown). Estimates of DV patency in $Ara9^{-/-}$ mice could not be obtained because these mice are resorbed or stillborn due to cardiac defects that begin around day E12 (Lin et al., 2007).

The presence of DV causes a significant decrease in liver weight. In addition to and as a result of the patent DV, another common phenotype observed in $Ahr^{-/-}$ mice is a decreased relative liver weight. To investigate whether this relationship also holds true for the $Ara9$ hypomorphic lines, we compared relative liver weights from wild-type, heterozygous hypomorphic, homozygous hypomorphic and heterozygous null animals. As expected, liver weight in $Ara9^{fxneofxneo}$ and $Ara9^{+/-}$ mice were significantly less than in wild-type and $Ara9^{+/fxneo}$ mice (Figure 3B).

MOL #47068

DISCUSSION

Characterization of the *Ahr*^{-/-} phenotype has defined a role for the AHR in a developmental pathway essential for the normal closure of the DV in the developing liver (Lahvis et al., 2000). Based on this observation, it follows that proteins which influence AHR folding, localization, or function may also be essential for AHR-mediated hepatovascular development. The simplest way to test this idea is to create mouse models with null alleles at candidate genes and examine their AHR-mediated response profile. Unfortunately, most, if not all of the proteins known to be involved in AHR signaling are not amenable to classic gene targeting approaches that employ null alleles, since many AHR-associated gene products are essential for more than one independent cellular pathway required for the survival of the animal. A relevant example is the ARNT protein, which is also required for developmental angiogenesis mediated by hypoxia-inducible factors (Chan et al., 1999; Maltepe et al., 1997). In the case of ARNT, we were able to overcome its essential nature and provide evidence for its role in AHR-mediated development by using mice that exhibited decreased expression of ARNT (i.e., hypomorphic expression) (Walisser et al., 2004b). In that model we found that decreased expression of the ARNT protein, allowed for normal embryonic angiogenesis, yet yielded a developmental phenotype that was identical to that observed in the *Ahr*^{-/-} model (i.e., a patent DV).

Given our recent study demonstrating that *Ara9*^{-/-} mice die in fetal development due to double outlet right ventricle (DORV) and ventricular septal defect (VSD), we chose to employ a “hypomorph strategy” similar to that used for ARNT (Lin et al., 2007; Walisser et al., 2004b). To this end, we constructed a series of recombinant alleles at the *Ara9* locus in mice. Our strategy was based on work from this lab and others, which has shown that targeted insertion of the *Neo* gene into a locus of interest frequently results in the generation of a hypomorphic allele (Walisser et al., 2004b). Given that *Neo*

MOL #47068

insertion was an intermediary step in generating a conditional *Ara9* allele, a hypomorphic allele of *Ara9* was constructed and used to characterize the influence of hypomorphic ARA9 expression on AHR-mediated liver development. It was our prediction the generation of a hypomorphic mouse would allow us to bypass embryonic lethality and enable us to study the effect of decreased ARA9 protein expression on AHR-mediated biology.

Using the *Ara9^{fxneo}* allele along with our previously generated *Ara9* allele, we created an allelic series where graded expression of the ARA9 protein could be achieved after appropriate genetic crosses. The expression levels of ARA9 protein ranged from highest to lowest in *Ara9^{+/+}*, *Ara9^{+/fxneo}*, *Ara9^{+/-}*, and *Ara9^{fxneo/fxneo}* mice, respectively (Figure 2A and data not shown). Although our western blot-derived estimates of ARA9 protein expression from these models provides only a semi-quantitative measure of relative protein expression, the data does support an estimate of approximately a 10 % expression of ARA9 in the *Ara9^{fxneo/fxneo}* mice, a 50 % expression in the *Ara9^{+/-}* mice and a 60 % expression in *Ara9^{+/fxneo}* mice relative to wild-type (Figure 2A).

Examination of a large cohort of *Ara9* mutants supports our two initial predictions. First, we found that mice homozygous for a hypomorphic *Ara9* allele (*Ara9^{fxneo/fxneo}*) proceeded through development in normal numbers (Figure 1) suggesting that 10 % of normal expression of ARA9 is sufficient to overcome the block in heart development observed previously in null animals (Lin et al., 2007). Secondly, we hypothesized that a marked reduction in ARA9 expression would lead to insufficient AHR signaling and the corresponding mice would display many of the phenotypes of *Ahr* null animals. Examination of the developmental phenotype, patent DV, was of particular interest to us. To this point, we measured the frequency of the DV and found 83 % of the hypomorphic animals to display this developmental phenotype (Figure 3). In addition to the phenocopy exhibited by *Ara9* hypomorphs and *Ahr* null animals, additional support for the importance of ARA9 in AHR-mediated DV closure came

MOL #47068

from the observation of a “dose effect” of ARA9 expression on these endpoints. A slight reduction of ARA9 protein levels by one copy of *Ara9^{fxneo}* (i.e., the *Ara9^{+/fxneo}* model) led to only a 10 % frequency of patent DV. Intermediate expression of ARA9 from the *Ara9^{+/-}* model display a patent DV incidence of 56 %. Even greater reduction of ARA9 protein from two copies of the hypomorphic allele (i.e., *Ara9^{fxneo/fxneo}*) led to an 83 % incidence of patent DV. In our examination of hundreds of wild-type mice (*Ara9*), we have never observed a patent DV. In keeping with this, we have observed a 0 % frequency of patent DV in our wild-type cohort. Taken in sum, these data support the idea that ARA9 plays an important role in AHR-mediated developmental signaling.

Due to the persistence of the DV in ARA9 hypomorphic animals, this model has less power as a tool to study the adaptive and toxic pathways mediated by the AHR. This concept is based upon the observation that the portocaval shunting, which accompanies a patent DV, can lead to aberrant disposition of TCDD and related AHR agonists in many tissues making a direct comparison between mutant and wild-type responses problematic (Thomae et al., 2004). For example, if we were trying to show a relationship between *Ara9* expression and TCDD toxicity for a given liver endpoint, we would predict a decreased potency in the *Ara9* hypomorphs. However, if this did occur, we would not know whether the attenuation was due to decreased cellular AHR signaling or to a decreased concentration of TCDD in the hepatic parenchyma due to shunting. Therefore, to understand the role ARA9 plays in toxic and adaptive signaling, our future plans include crossing the *Ara9^{fxneo}* hypomorph with the FLPeR line (mice containing Flp-Recombinase driven by the GTSRosa promoter), thereby allowing for germ-line excision of the neomycin cassette and creation of a conditional *ARA9* mouse (Dymecki, 1996). These mice can then be crossed to mice where expression of Cre is driven by the Albumin promoter, allowing for specific excision of the *Ara9* allele in hepatocytes (Kellendonk et al., 2000). Such a model will allow us to understand the

MOL #47068

relationship between hepatic expression of ARA9 and AHR-mediated hepatotoxicity and adaptive metabolism.

MOL #47068

ACKNOWLEDGEMENTS

The authors would like to thank Erin Hsu, Susan Moran, and Brian McIntosh for their critical reading of this manuscript.

MOL #47068

REFERENCES

- Carver LA and Bradfield CA (1997) Ligand-dependent interaction of the aryl hydrocarbon receptor with a novel immunophilin homolog in vivo. *J Biol Chem* **272**(17):11452-11456.
- Chan WK, Yao G, Gu YZ and Bradfield CA (1999) Cross-talk between the aryl hydrocarbon receptor and hypoxia inducible factor signaling pathways. Demonstration of competition and compensation. *J Biol Chem* **274**(17):12115-12123.
- Devore J and Peck R (1986) *Statistics: The Exploration and Analysis of Data*. West Publishing Co., New York.
- Dymecki SM (1996) Flp recombinase promotes site-specific DNA recombination in embryonic stem cells and transgenic mice. *Proc Natl Acad Sci USA* **93**:6191-6196.
- Eisen HJ, Hannah RR, Legraverend C, Okey AB and Nebert DW (1983) The Ah-receptor: Controlling factor in the induction of drug-metabolizing enzymes by certain chemical carcinogens and other environmental pollutants. *Biochemical Actions of Hormones* **10**:227-257.
- Fernandez-Salguero PM, Hilbert DM, Rudikoff S, Ward JM and Gonzalez FJ (1996) Aryl-hydrocarbon receptor-deficient mice are resistant to 2,3,7,8-tetrachlorodibenzo-p-dioxin-induced toxicity. *Toxicology & Applied Pharmacology* **140**(1):173-179.
- Henry EC and Gasiewicz TA (1993) Transformation of the aryl hydrocarbon receptor to a DNA-binding form is accompanied by release of the 90-kDa heat-shock protein and increased affinity for 2,3,7,8-tetrachlorodibenzo-p-dioxin. *Biochem* **294**:95-101.
- Hollingshead BD, Petrusis JR and Perdew GH (2004) The Ah receptor transcriptional regulator XAP2 antagonizes p23 binding to Ah receptor/Hsp90 complexes and is dispensable for receptor function. *J Biol Chem*.
- Hord NG and Perdew GH (1994) Physicochemical and immunocytochemical analysis of the aryl hydrocarbon receptor nuclear translocator: characterization of two monoclonal antibodies to the aryl hydrocarbon receptor nuclear translocator. *Molecular Pharmacology* **46**(4):618-626.
- Kellendonk C, Opherck C, Anlag K, Schutz G and Tronche F (2000) Hepatocyte-specific expression of Cre recombinase. *Genesis* **26**(2):151-153.
- Lahvis G, Lindell S, Thomas R, McCuskey R, Murphy C, Glover E, Bentz M, Southard J and Bradfield C (2000) Portosystemic shunts and persistent fetal vascular structures in Ah-receptor deficient mice. *Proc Natl Acad Sci U S A* **97**:10442-10447.
- Lahvis GP, Pyzalski RW, Glover E, Pitot HC, McElwee MK and Bradfield CA (2005) The aryl hydrocarbon receptor is required for developmental closure of the ductus venosus in the neonatal mouse. *Mol Pharmacol* **67**(3):714-720.
- Lin BC, Sullivan R, Lee Y, Moran S, Glover E and Bradfield CA (2007) Deletion of the aryl hydrocarbon receptor-associated protein 9 leads to cardiac malformation and embryonic lethality. *J Biol Chem* **282**(49):35924-35932.
- Ma Q and Whitlock JP, Jr. (1997) A novel cytoplasmic protein that interacts with the Ah receptor, contains tetratricopeptide repeat motifs, and augments the transcriptional response to 2,3,7,8-tetrachlorodibenzo-p-dioxin. *J Biol Chem* **272**(14):8878-8884.
- Maltepe E, Schmidt JV, Baunoch D, Bradfield CA and Simon MC (1997) Abnormal angiogenesis and responses to glucose and oxygen deprivation in mice lacking the protein ARNT. *Nature* **386**(6623):403-407.

MOL #47068

- Meyer BK and Perdew GH (1999) Characterization of the AhR-hsp90-XAP2 core complex and the role of the immunophilin-related protein XAP2 in AhR stabilization. *Biochemistry* **38**(28):8907-8917.
- Poland A (1982) Induction of the drug-metabolizing enzymes. *IARC Scientific Publications - Lyon* **39**(351-364).
- Poland A and Knutson JC (1982) 2,3,7,8-tetrachlorodibenzo-p-dioxin and related halogenated aromatic hydrocarbons: examination of the mechanism of toxicity. *Annual Review of Pharmacology & Toxicology* **22**:517-554.
- Reyes H, Reisz-Porszasz S and Hankinson O (1992) Identification of the Ah receptor nuclear translocator protein (Arnt) as a component of the DNA binding form of the Ah receptor. *Science* **256**(5060):1193-1195.
- Schermerhorn T, Center SA, Dykes NL, Rowland PH, Yeager AE, Erb HN, Oberhansley K and Bonda M (1996) Characterization of hepatoportal microvascular dysplasia in a kindred of Cairn Terriers. *J Veterinary Int Med* **10**:219-230.
- Schmidt JV, Su GH, Reddy JK, Simon MC and Bradfield CA (1996) Characterization of a murine Ahr null allele: involvement of the Ah receptor in hepatic growth and development. *Proc Natl Acad Sci U S A* **93**(13):6731-6736.
- Shetty PV, Bhagwat BY and Chan WK (2003) P23 enhances the formation of the aryl hydrocarbon receptor-DNA complex. *Biochem Pharmacol* **65**(6):941-948.
- Thomae TL, Glover E and Bradfield CA (2004) A maternal Ahr null genotype sensitizes embryos to chemical teratogenesis. *J Biol Chem* **279**(29):30189-30194.
- Walisser JA, Bunker MK, Glover E and Bradfield CA (2004a) Gestational exposure of Ahr and Arnt hypomorphs to dioxin rescues vascular development. *Proc Natl Acad Sci U S A* **101**(47):16677-16682.
- Walisser JA, Bunker MK, Glover E, Harstad EB and Bradfield CA (2004b) Patent ductus venosus and dioxin resistance in mice harboring a hypomorphic Arnt allele. *J Biol Chem* **279**(16):16326-16331.

MOL #47068

MOL #47068

FOOTNOTES

This work was supported by National Institutes of Health Grants R01-ES006883, T32-CA009135, and P30-CA014520. The costs of publication of this article were defrayed in part by the payment of page charges. This article must therefore be hereby marked “*advertisement*” in accordance with 18 U.S.C. Section 1734 solely to indicate this fact.

All requests for reprints should be directed to Christopher Bradfield, Ph.D., 1400 University Ave, Madison, WI, 53706. Phone: 608-262-2024; Fax: 608-262-2824; E-mail: bradfield@oncology.wisc.edu

MOL #47068

FIGURE LEGENDS

Fig 1. Targeting vector and Southern blot analysis for *Ara9^{fxneo}* targeting construct.

A. Genomic DNA of *Ara9*, the targeting vector, and a map of *Ara9^{fxneo}* homologous recombination. **B.** Southern blot analysis of *Ara9^{fxneo}* ES cell that has undergone homologous recombination. The wild-type band is present at 2.7 kb and homologous recombination is depicted at 3.9 kb. **C.** Mendelian distribution of genotypes in hypomorphic *Ara9* animals. *Legend.* Lines denote regions of homology. B = *BamHI*, P = Probe, X = exon, Neo = Neomycin Cassette, L = Lox P, F = Frt Site, +/+ = wild-type, +/*fxneo* = heterozygote, *fxneo/fxneo* = homozygote.

Fig 2. Western blot analysis of *Ara9^{fxneo}* mice shows decrease in ARA9 protein levels. **A.** Western blot of *Ara9^{fxneo}* protein comparing wildtype *Ara9^{+/+}* and homozygous *Ara9^{fxneo/fxneo}* littermates in heart, liver, kidney, spleen, and thymus. **B.** Western blot of *Ara9^{fxneo/fxneo}* and *Ara9^{+fxneo}* protein compared to a wild-type *Ara9^{+/+}* gradient in the thymus. **C.** Western blot of *Ara9^{+/-}* protein compared to wild-type *Ara9^{+/+}* in thymus. The ARA9 protein band was detected with a mouse monoclonal FKBP domain-specific antibody.

Fig 3. Visualization of ductus venosus and incidence of occurrence in *Ara9* hypomorphic or

heterozygous mice. **A.** Radio images showing presence of a ductus venosus in *Ara9^{fxneo/fxneo}* mouse. The C57BL/6 liver (left) is shown as comparison for a wild-type (well-perfused liver). An *Ahr^{-/-}* liver (center) is shown as a representative of a poorly-perfused liver with ductus venosus. An *Ara9^{-/-}* liver (right) is also shown with a poorly perfused liver with ductus venosus. **B.** A gradient of ARA9 expression leads to a gradient in the presentation of ductus venosus & liver weight in *Ara9^{fxneo}* and *Ara9^{+/-}* mice. The percentage of animals with DV (# of animals/total animals) in *Ara9^{fxneo}* or *Ara9^{+/-}* mice is shown. Liver

MOL #47068

weight of all mice within a given genotype is represented as a percentage of total body weight \pm standard deviation. A statistical analysis using a one-way ANOVA shows a significant difference between livers of wild-type and *Ara9*^{+/*fxneo*} animals versus *Ara9*^{*fxneo/fxneo*} and *Ara9*^{+/-} mice (*p < 0.01).

1A.

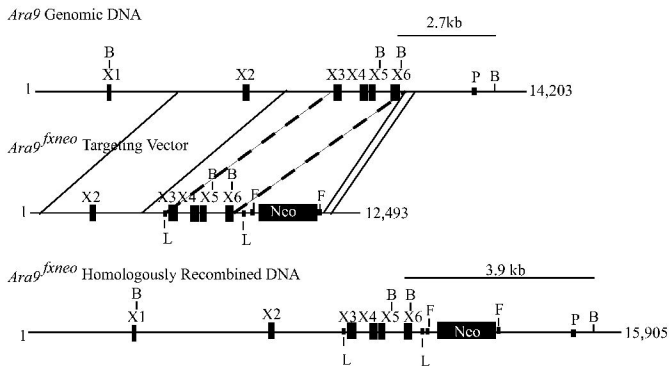

1B.

Ara9^{fxneo} Genotype

+/+ +/fxneo fxneo/fxneo



1C.

Genotype	# Animals
<i>Ara9</i> ^{+/+}	12/52 (23%)
<i>Ara9</i> ^{+/fxneo}	30/52 (58%)
<i>Ara9</i> ^{fxneo/fxneo}	10/52 (19%)

2A.

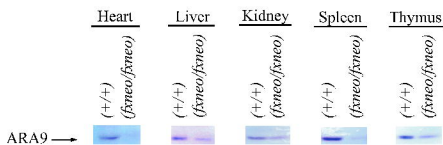

2B.

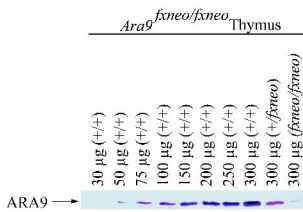

2C.

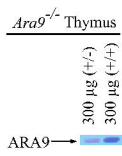

3A.

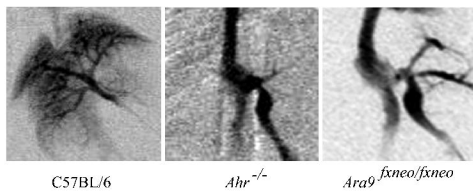

3B.

<u>Genotype</u>	<u>% With DV</u>	<u>Relative Liver Weight</u>
<i>Ara9</i> ^{+/+}	0% (0/16)	5.42% ± 0.01
<i>Ara9</i> ^{+/fxneo}	10% (1/10)	5.65% ± 0.01
<i>Ara9</i> ^{+/-}	56% (5/9)	3.73% ± 0.00
<i>Ara9</i> ^{<i>fxneo/fxneo</i>}	83% (5/6)	3.98% ± 0.01